

GEWA

STRINGS



distribution catalog
02|2019

General information

Business hours:

Monday - Thursday: 7.30 to 18.00
Friday: 7.30 to 16.45

After business hours:

Faxed or E-mail orders can be sent at any hour.

Prices (see separate price list)

Prices indicated in EURO refer to shipments EXW Adorf, Germany.

Prices indicated in USD refer to FCL shipments FOB China.

Prices are as per latest price list and are subject to change.

Shipping Information

Please refer to price list for shipping details.

International Sales:

Phone: + 49 (0) 37423 / 778 333

Fax: + 49 (0) 37423 / 778 9333

* Items can be supplied FOB China

index

string instruments and accessories

- 3 violins
- 16 violas
- 20 cello
- 30 double basses
- 52 bows
- 61 mutes
- 62 end pins
- 64 pegs
- 67 tailpieces
- 67 chin rests
- 70 bow hair
- 71 stands
- 72 laquering accessories
- 74 tools

bags and accessories

- 78 cello gig-bag
- 78, 80 double bass gig-bag

cases and accessories

- 81, 86, 138 violin form shaped case
- 82, 96, 140 violin case
- 84, 126, 138 viola form shaped case
- 84, 130, 146 viola case
- 85, 148 cello case
- 85, 160 double bass case
- 162 bow case
- 164 straps and replacement fittings



GEWA
master workshop

MODULAR SYSTEM ALLEGRO-VL1

NEW

„Over the last years GEWA has set up a production for bowed instruments. A specifically devised operational and organisational structure as well as state-of-the-art, computerised CNC machines provide the basis for this manufacture that sets a new standard worldwide; processing, preparation and precision live up to the highest demands for every instrument. In addition, only European tonewood is being used, ensuring outstanding sound characteristics in its quality.

Skilled luthiers apply a hand varnish to the perfect “white instrument” that up to now has not been existing in this price range. All features of this extraordinary instrument series result in a sound reproduction that redefines this price segment.“

signed: Marko Ackert (Master Luthier)

The violin Allegro-VL1 is available as **basic instrument**, equipped with **soundpost**, pre-adjusted **bridge** and **upper nut** as well as **fingerboard**, **pegs** and **chin rest** made of ebony (**Art-Nr. GS400.051.000.0**).

The colour code in the price table relates to the chosen options at delivery

not set up
 safe for transport (bridge and soundpost down for safe transport)
 set up





The basic model can be fitted suiting individual demands (see table).

To determine the required configuration of the violin / violin outfits the following options are available – please add the respective figures.

Example item number:

GS400.051. 2 1 1 . 1



Violin 4/4 (Basic-instrument)	Delivered as	Case	Bow	Strings incl. tailpiece
GS400.051.	0 Not set up	0 without case	0 without bow	0 without strings and tailpiece
	1 Safe for transport (bridge and soundpost down for safe transport) incl. • Ebony fittings • Original Aubert bridge • Wittner fine tuning tailpiece • Thomastik-Infeld AlphaYue strings • Ebony chin rest	1 with violin form case 	1 with Massaranduba bow 	1 with Thomastik Infeld Alphayue strings 
	2 set up incl. • Ebony fittings • Original Aubert bridge • Wittner fine tuning tailpiece • Thomastik-Infeld AlphaYue strings • Ebony chin rest	2 with violin oblong case 	2 with carbon bow 	

GEWA Violin Allegro-VL1

- **Back and sides made of solid EUROPEAN Maple**
- **Solid EUROPEAN Spruce top**
- **Brown-amber coloured natural resin varnish**
- **Hand varnish**
- Inserted purfling
- Ebony fittings
- **Original Aubert bridge, pre-adjusted**
- **Wittner fine tuning tailpiece** (optional; see above)
- **Thomastik-Infeld AlphaYue strings** (optional; see above)
- Ebony chin rest
- Rosin (optional; see above)
- Massaranduba / Carbon bow with natural hair (optional; see above)
- Violin form or oblong case with screw-attached cover, rucksack straps and reflectors (optional; see above)
- Minimal colour variation possible due to hand-varnished treatment
- **Not set up: without label;** all other options without label
- If generally “without label”, please inform



GEWA Strings

GS400.051.000.0	4/4	without setup, with pre-adjusted bridge
GS400.051.010.0	4/4	without setup, pre-adjusted bridge incl. form case
GS400.051.020.0	4/4	without setup, with pre-adjusted bridge, incl. oblong violin case
GS400.051.100.1	4/4	with set up
GS400.051.111.1	4/4	Setup incl. form case, Massaranduba bow, AlphaYue strings
GS400.051.112.1	4/4	Setup incl. form case, carbon bow, AlphaYue strings
GS400.051.121.1	4/4	Setup incl. oblong violin case, Massaranduba bow, AlphaYue strings
GS400.051.122.1	4/4	Setup incl. oblong violin case, carbon bow, AlphaYue strings
GS400.051.200.1	4/4	with set up
GS400.051.211.1	4/4	TOPSELLER with setup incl. form case, Massaranduba bow, AlphaYue strings
GS400.051.212.1	4/4	Setup incl. form case, carbon bow, AlphaYue strings
GS400.051.221.1	4/4	TOPSELLER Setup incl. oblong violin case, Massaranduba bow, AlphaYue strings
GS400.051.222.1	4/4	Setup incl. oblong violin case, carbon bow, AlphaYue strings
GS400.051.000.0L	4/4 lefthand	without setup, with pre-adjusted bridge
GS400.051.010.0L	4/4 lefthand	without setup, with pre-adjusted bridge, incl. form case
GS400.051.020.0L	4/4 lefthand	without setup, with pre-adjusted bridge incl. oblong violin case
GS400.051.100.1L	4/4 lefthand	with set up
GS400.051.111.1L	4/4 lefthand	Setup incl. form case, Massaranduba bow, AlphaYue strings
GS400.051.112.1L	4/4 lefthand	Setup incl. form case, carbon bow, AlphaYue strings
GS400.051.121.1L	4/4 lefthand	Setup incl. violin case, Massaranduba bow, AlphaYue strings
GS400.051.122.1L	4/4 lefthand	Setup incl. oblong violin case, carbon bow, AlphaYue strings
GS400.051.200.1L	4/4 lefthand	with set up
GS400.051.211.1L	4/4 lefthand	Setup incl. form case, Massaranduba bow, AlphaYue strings
GS400.051.212.1L	4/4 lefthand	Setup incl. form case, carbon bow, AlphaYue strings
GS400.051.221.1L	4/4 lefthand	Setup incl. violin case, Massaranduba bow, AlphaYue strings
GS400.051.222.1L	4/4 lefthand	Setup incl. oblong violin case, carbon bow, AlphaYue strings
GS400.052.000.0	3/4	without setup, with pre-adjusted bridge
GS400.052.010.0	3/4	without setup, with pre-adjusted bridge, incl. form case
GS400.052.020.0	3/4	without setup, with pre-adjusted bridge incl. oblong violin case
GS400.052.100.1	3/4	with set up
GS400.052.111.1	3/4	Setup incl. form case, Massaranduba bow, AlphaYue strings
GS400.052.112.1	3/4	Setup incl. form case, carbon bow, AlphaYue strings
GS400.052.121.1	3/4	Setup incl. violin case, Massaranduba bow, AlphaYue strings
GS400.052.122.1	3/4	Setup incl. oblong violin case, carbon bow, AlphaYue strings
GS400.052.200.1	3/4	with set up
GS400.052.211.1	3/4	TOPSELLER Setup incl. form case, Massaranduba bow, AlphaYue strings
GS400.052.212.1	3/4	Setup incl. form case, carbon bow, AlphaYue strings
GS400.052.221.1	3/4	TOPSELLER Setup incl. violin case, Massaranduba bow, AlphaYue strings
GS400.052.222.1	3/4	Setup incl. oblong violin case, carbon bow, AlphaYue strings
GS400.053.000.0	1/2	without setup, with pre-adjusted bridge
GS400.053.010.0	1/2	without setup, with pre-adjusted bridge, incl. form case
GS400.053.020.0	1/2	without setup, with pre-adjusted bridge incl. oblong violin case
GS400.053.100.1	1/2	with set up
GS400.053.111.1	1/2	Setup incl. form case, Massaranduba bow, AlphaYue strings
GS400.053.112.1	1/2	Setup incl. form case, carbon bow, AlphaYue strings
GS400.053.121.1	1/2	Setup incl. violin case, Massaranduba bow, AlphaYue strings
GS400.053.122.1	1/2	Setup incl. oblong violin case, carbon bow, AlphaYue strings
GS400.053.200.1	1/2	with set up
GS400.053.211.1	1/2	TOPSELLER Setup incl. form case, Massaranduba bow, AlphaYue strings
GS400.053.212.1	1/2	Setup incl. form case, carbon bow, AlphaYue strings
GS400.053.221.1	1/2	TOPSELLER Setup incl. violin case, Massaranduba bow, AlphaYue strings
GS400.053.222.1	1/2	Setup incl. oblong violin case, carbon bow, AlphaYue strings
GS400.054.000.0	1/4	without setup, with pre-adjusted bridge
GS400.054.010.0	1/4	without setup, with pre-adjusted bridge, incl. form case
GS400.054.020.0	1/4	without setup, with pre-adjusted bridge incl. oblong violin case
GS400.054.100.1	1/4	with set up
GS400.054.111.1	1/4	Setup incl. form case, Massaranduba bow, AlphaYue strings
GS400.054.112.1	1/4	Setup incl. form case, carbon bow, AlphaYue strings
GS400.054.121.1	1/4	Setup incl. violin case, Massaranduba bow, AlphaYue strings
GS400.054.122.1	1/4	Setup incl. oblong violin case, carbon bow, AlphaYue strings
GS400.054.200.1	1/4	with set up
GS400.054.211.1	1/4	TOPSELLER Setup incl. form case, Massaranduba bow, AlphaYue strings
GS400.054.212.1	1/4	Setup incl. form case, carbon bow, AlphaYue strings
GS400.054.221.1	1/4	TOPSELLER Setup incl. violin case, Massaranduba bow, AlphaYue strings
GS400.054.222.1	1/4	Setup incl. oblong violin case, carbon bow, AlphaYue strings

MODULAR SYSTEM IDEALE-VL2

NEW

„Over the last years GEWA has set up a production for bowed instruments. A specifically devised operational and organisational structure as well as state-of-the-art, computerised CNC machines provide the basis for this manufacture that sets a new standard worldwide; processing, preparation and precision live up to the highest demands for every instrument. In addition, only European tonewood is being used, ensuring outstanding sound characteristics in its quality.

Skilled luthiers apply a hand varnish to the perfect “white instrument” that up to now has not been existing in this price range. All features of this extraordinary instrument series result in a sound reproduction that redefines this price segment.“

signed: Marko Ackert (Master Luthier)

The violin Ideale-VL2 is available as **basic instrument**, equipped with **soundpost**, pre-adjusted **bridge** and **upper nut** as well as **fingerboard**, **pegs** and **chin rest** made of ebony (**Art-Nr. GS400.061.000.0**).

The colour code in the price table relates to the chosen options at delivery





not set up
 safe for transport (bridge and soundpost down for safe transport)
 set up

The basic model can be fitted suiting individual demands (see table). To determine the required configuration of the violin / violin outfits the following options are available – please add the respective figures.

Example item number:

GS400.061.2 1 1 . 1



Violin 4/4 (Basic-instrument)	Delivered as	Case	Bow	Strings incl. tailpiece
GS400.061.	0 Not set up	0 without case	0 without bow	0 without strings and tailpiece
	1 Safe for transport <i>(bridge and soundpost down for safe transport)</i> incl. • Ebony fittings • Original Aubert bridge • Wittner fine tuning tailpiece • Thomastik-Infeld AlphaYue strings • Ebony chin rest	1 with violin form case 	1 with Massaranduba bow 	1 with Thomastik Infeld Alphayue strings 
	2 set up incl. • Ebony fittings • Original Aubert bridge • Wittner fine tuning tailpiece • Thomastik-Infeld AlphaYue strings • Ebony chin rest	2 with violin oblong case 	2 with carbon bow 	

GEWA Violin Ideale-VL2

- Back and sides made of **solid EUROPEAN MAPLE**
- **Medium flamed**
- Solid **EUROPEAN SPRUCE TOP**
- **Red-brown natural resin varnish**
- **Hand varnish**
- Inserted purfling
- Ebony fittings
- **Original Aubert bridge, pre-adjusted**
- **Wittner fine tuning tailpiece** (optional; see above)
- **Thomastik-Infeld AlphaYue strings** (optional; see above)
- Ebony chin rest
- Rosin (optional; see above)
- Massaranduba / Carbon bow with natural hair (optional; see above)
- Violin form case / violin oblong case with screw-attached cover, rucksack straps and reflectors (optional; see above)
- Minimal colour variation possible due to hand-varnished treatment
- **Not set up: without label**; all other options including label
- If generally “without label”, please inform



GEWA Strings

GEWA Violin Maestro 6

- **Advanced Student Violin**
- Back and sides made of solid Maple
- Solid Spruce top
- Better flamed back
- Maroon natural resin varnish, slightly shaded
- Inserted purfling
- Ebony fingerboard and pegs



GS400.071	4/4	
GS400.071.100	4/4	Set-up
GS400.072	3/4	
GS400.072.100	3/4	Set-up
GS400.073	1/2	
GS400.073.100	1/2	Set-up
GS400.074	1/4	
GS400.074.100	1/4	Set-up
GS400.075	1/8	
GS400.075.100	1/8	Set-up

GEWA Violin Maestro 6

- **Advanced Student Violin**
- Back and sides made of solid Maple
- Solid Spruce top
- Better flamed back
- Maroon natural resin varnish, slightly shaded
- Inserted purfling
- Ebony fingerboard and pegs

Model antique



GS400.081	4/4 Antique	
GS400.081.100	4/4 Antique	Set-up
GS400.082	3/4 Antique	
GS400.082.100	3/4 Antique	Set-up
GS400.083	1/2 Antique	
GS400.083.100	1/2 Antique	Set-up
GS400.084	1/4 Antique	
GS400.084.100	1/4 Antique	Set-up

GEWA Strings

GEWA Violin Maestro 11

- **Advanced Student Violin**
- **French Style**
- Back and sides made of solid Maple
- Solid spruce top with fine grains
- Better flamed back
- Transparent maroon natural resin varnish, strongly shaded
- Antique spirit hand varnished
- Inserted purfling
- Ebony fingerboard and pegs



GS400.088	4/4	
GS400.088.100	4/4	Set-up

GEWA Violin Maestro 26

- **Violin for the demanding music student**
- Back and sides solid Maple - **beautifully flamed**
- Solid Siberian spruce top with fine grains
- Inserted purfling
- Ebony fingerboard and pegs
- **Spirit hand varnish** - dark brown/amber colour
- Slightly antique

NEW



GS400.126	4/4	
GS400.126.100	4/4	set-up
GS.400.127.100	4/4 Guarneri	set-up
GS400.127	4/4 Guarneri	

GEWA Violin Maestro 41

- **Advanced Student Violin**
- Back and sides made of solid Maple
- Solid spruce top with fine grains
- Exceptionally beautiful, deep flamed back
- Dark red brown transparent natural resin varnish, slightly shaded
- Hand varnished
- Inserted purfling
- Ebony fingerboard and pegs



GS400.151	4/4	
GS400.151.100	4/4	Set-up
GS400.161	4/4 Antique	
GS400.161.100	4/4 Antique	Set-up
GS400.162	4/4 Guarneri Antique	
GS400.162.100	4/4 Guarneri Antique	Set-up
GS400.163	7/8 antique	
GS400.163.100	7/8 antique	Set-up

GEWA Strings

GEWA Violin Maestro 46

- **Violin for the demanding music student**
- **German Style**
- Back made of solid **European sycamore**
- Solid, fine **German spruce top**
- Well flamed back
- European red-brown transparent natural resin varnish
- **Antique spirit hand-varnished**
- Inserted purfling
- Ebony fingerboard and pegs



GS400.165	4/4	
GS400.165.100	4/4	Set-up
GS400.166	4/4	Guarneri
GS400.166.100	4/4	Guarneri Set-up

GEWA Violin Maestro 51

- **Violin for the demanding music student**
- Back and sides made of solid Maple
- Solid Spruce top
- **One part, beautifully flamed back**
- Dark red brown transparent natural resin varnish, slightly shaded
- **Antique spirit, hand varnished**
- Inserted purfling
- Ebony fingerboard and pegs



GS400.181	4/4	
GS400.181.100	4/4	Set-up
GS400.182	4/4	Guarneri
GS400.182.100	4/4	Guarneri Set-up

GEWA Violin Maestro 56

- **Advanced Student Violin**
- **French Style**
- Back made out of solid **EUROPEAN** maple
- Solid, german spruce top with fine annual rings
- Better flamed back
- European red brown transparent natural resin varnish
- **Antique spirit hand-varnished**
- Inserted purfling
- Ebony fingerboard and pegs



GS400.185	4/4	
GS400.185.100	4/4	Set-up

GEWA Violin Maestro 71

- **Advanced Student Violin**
- **Italian Style**
- Back made out of solid **Bosnian Sycamore**
- **Solid, Italian spruce top with fine annual rings**
- Deeply flamed back
- Italian red brown transparent natural resin varnish
- Antique spirit hand varnished
- Inserted purfling
- Ebony fingerboard and pegs



GS400.195	4/4	
GS400.195.100	4/4	Set-up
GS400.196	4/4	Guarneri
GS400.196.100	4/4	Guarneri Set-up

GEWA Strings

GEWA Violin Germania 11

- **Concert Violin**
- **Conception: luthier Marko Ackert**
- **„Made in Germany“**
- **Production in workshop of GEWA Adorf**
- Selected Bosnian sycamore maple
- Manufactured and calibrated for the best possible sound, selected Spruce top
- Open-pore hand varnish, spirit-based
- **Very good response thanks to thin varnish layer**
- Ebony fingerboard and pegs
- **Delivered set-up upon request**



Model antique

GS400.510	4/4 Model Berlin antique	
GS400.510.100	4/4 Model Berlin antique	Set-up
GS400.520	4/4 model Berlin	
GS400.520.100	4/4 model Berlin	Set-up



Model antique

GS400.511	4/4 Model Rom antique	
GS400.511.100	4/4 Model Rom antique	Set-up
GS400.521	4/4 model Rome	
GS400.521.100	4/4 model Rome	Set-up

GEWA Strings

GEWA Violin Germania 11

- **Concert Violin**
- **Conception: luthier Marko Ackert**
- **„Made in Germany“**
- **Production in workshop of GEWA Adorf**
- Selected Bosnian sycamore maple
- Manufactured and calibrated for the best possible sound, selected Spruce top
- Open-pore hand varnish, spirit-based
- **Very good response thanks to thin varnish layer**
- Ebony fingerboard and pegs
- **Delivered set-up upon request**



Model antique

GS400.512	4/4 Model Prag antique	
GS400.512.100	4/4 Model Prag antique	Set-up
GS400.522	4/4 model Prague	
GS400.522.100	4/4 model Prague	Set-up



Model antique

GS400.514	4/4 Model Paris antique	
GS400.514.100	4/4 Model Paris antique	Set-up
GS400.524	4/4 model Paris	
GS400.524.100	4/4 model Paris	Set-up

GEWA Strings

GEWA Concert violin Georg Walther

- **Master violin**
- **Conception: luthier Marko Ackert**
- **„Made in Germany“**
- **Stradivari model**
- Hand selected, nicely flamed sycamore back
- Solid spruce top with fine grains
- Nicely flamed back
- Red brown natural resin varnish, slightly shaded
- Hand varnished
- Inserted purfling
- Ebony fingerboard and pegs
- **Hand-made in our GEWA master workshops**
- **Delivered set-up upon request**



GS400.650 4/4

GS400.650.100 4/4 Set-up

GEWA Concert violin Georg Walther

- **Master Violin**
- **Conception: luthier Marko Ackert**
- **„Made in Germany“**
- Hand selcted, beautiful flamed back made out of Sycamore maple
- Manufactured and calibrated for the best possible sound, selected Spruce top
- Finest, selected European tonewood, highest quality
- Gold yellow transparent natural resin varnish
- Hand varnished
- Inserted purfling
- Matching ebony fittings
- **Hand-made in our GEWA master workshops**
- **Delivered set-up upon request**



GS400.690 4/4

GS400.690.100 4/4 Set-up

GEWA Concert violin Georg Walther

- **Master Violin**
- **Conception: luthier Marko Ackert**
- **„Made in Germany“**
- Hand selected, nicely flamed Sycamore maple back
- Manufactured and calibrated for the best possible sound, selected Spruce top
- fine, selected European tonewood
- Gold-brown natural resin varnish, slightly shadowed
- Antique spirit hand varnished
- Inserted purfling
- Matching ebony fittings
- **Hand-made in our GEWA master workshops**
- **Delivered set-up upon request**



GS400.680 4/4

GS400.680.100 4/4 Set-up

GEWA Concert violin Georg Walther

- **Master Violin**
- **Conception: luthier Marko Ackert**
- **„Made in Germany“**
- Hand selcted, beautiful flamed back made out of Sycamore maple
- Manufactured and calibrated for the best possible sound, selected Spruce top
- Finest, selected European tonewood, highest quality
- Gold yellow transparent natural resin varnish
- **Antique hand varnish**
- Inserted purfling
- Matching ebony fittings
- **Hand-made in our GEWA master workshops**
- **Delivered set-up upon request**



GS400.691 4/4

GS400.691.100 4/4 Set-up

GEWA Strings

GEWA Soloist violin Meister

- Violin master luthier Norbert Knappe
- „Made in Germany“
- Guarneri model – La Campanella
- Hand selected, beautifully flamed sycamore back
- Fine-grained spruce top, calibrated sound
- Spirit hand-varnished
- Ebony fingerboard
- Pegs, tailpiece, end button and chinrest made of boxwood or optional ebony
- Inserted purfling
- Il Canone Soloist strings
- **Delivered set-up**
- **Incl. certificate of authenticity and brandmark**



GS400.800 4/4

GEWA Soloist violin Meister

NEW

- Violin master luthier Norbert Knappe
- „Made in Germany“
- Stradivari model - Le Streghe
- Hand selected, beautifully flamed sycamore back
- Finely grained spruce top, calibrated to best sound
- Spirit hand varnished
- Ebony fingerboard
- Pegs, tailpiece, end button and chinrest made of boxwood or ebony
- Inserted purfling
- Il Canone Soloist strings
- **Delivered set-up**
- **Incl. certificate of authenticity and brandmark**

NEW



GS400.850 4/4

GEWA E-violin Novita 3.0

- Concept/ development: Gewa Adorf, product manager Thomas Böhme
- Function-oriented design: the basic dimensions of a classical violin are kept
- Silk matt finish, the wood structure remains visible
- Solid maple neck
- Designer scroll
- Wittner fine tuning peg
- Wittner chin rest Zürich
- Wittner tailpiece
- Wittner shoulder rest Isny
- Aubert bridge
- Thomastik-Infeld strings AlhaYue
- Especially developed GEWA-pickup
- Piezo-system is mounted directly on the bridge (optionally left or right)
- Optional output between headphones and pre-amp
- Fits into every GEWA etui
- Including 3 paddings for etui
- Batteries not included
- Weight: approx. 550 g



GS400.300 Black

GS400.301 Red-brown

GS400.302 Gold-brown

GEWA Strings

GEWA E-violin

- Solid wooden body
- Ebony fittings
- Active Piezo bridge pick-up
- With headphones
- With volume control
- Ebony chin rest
- Special shoulder rest
- Rosin
- Bow with natural hair and ebony frog
- Case with screw-attached cover, rucksack straps
- **Set-up**



GS401.645 Red brown transparent varnish

GEWAPURE Violin outfit HW

- **Hardwood fittings**
- Back and sides solid Maple
- Solid Spruce top
- Inserted purfling
- Dark red-brown varnish
- Chin rest
- Fine tuning tailpiece
- Massaranduba bow
- Rosin
- Light case with screw-attached cover and attached music sheet pocket
- Carrying strap
- Incl. all parts
- Set-up



PS401.611*	4/4
PS401.612*	3/4
PS401.613*	1/2
PS401.614*	1/4
PS401.615*	1/8
PS401.616*	1/16

GEWAPURE Violin outfit EW

- **Ebony fittings**
- Back and sides made of solid maple
- Solid spruce top
- Inserted purfling
- Dark red-brown varnish
- chin rest
- Tailpiece with fine tuners
- Massaranduba bow with ebony frog
- Rosin
- **Black Design**
- **Light case with screw attached cover and sewn-on music sheet pocket**
- Carrying strap
- incl. all parts
- Set-up



GS401.646 White Finish



GS401.647 Black finish



PS401.621*	4/4
PS401.622*	3/4
PS401.623*	1/2
PS401.624*	1/4
PS401.625*	1/8
PS401.626*	1/16

GEWA Strings

GEWA Viola Maestro 6

- **Advanced Student Viola**
- Back and sides made of solid Maple
- Solid Spruce top
- Better flamed back
- Maroon natural resin varnish, slightly shaded
- Inserted purfling
- Ebony fingerboard and pegs



GEWA Viola Maestro 41

- **Advanced Student Viola**
- Back and sides made of solid Maple
- Solid spruce top with fine grains
- Exceptionally beautiful, deep flamed back
- Dark red brown transparent natural resin varnish, slightly shaded
- Hand varnished
- Inserted purfling
- Ebony fingerboard and pegs



GS401.771	35,5 cm	
GS401.771.100	35,5 cm	Set-up
GS401.772	38,2 cm	
GS401.772.100	38,2 cm	Set-up
GS401.773	39,5 cm	
GS401.773.100	39,5 cm	Set-up
GS401.774	40,8 cm	
GS401.774.100	40,8 cm	Set-up
GS401.775	42,0 cm	
GS401.775.100	42,0 cm	Set-up
GS401.781	35,5 cm Antique	
GS401.781.100	35,5 cm Antique	Set-up
GS401.782	38,2 cm Antique	
GS401.782.100	38,2 cm Antique	Set-up
GS401.783	39,5 cm Antique	
GS401.783.100	39,5 cm Antique	Set-up
GS401.784	40,8 cm Antique	
GS401.784.100	40,8 cm Antique	Set-up
GS401.785	42,0 cm Antique	
GS401.785.100	42,0 cm Antique	Set-up

GS401.863	39,5 cm Antique	
GS401.863.100	39,5 cm Antique	Set-up
GS401.864	40,8 cm Antique	
GS401.864.100	40,8 cm Antique	Set-up
GS401.865	42,0 cm Antique	
GS401.865.100	42,0 cm Antique	Set-up

GEWA Strings

GEWA Viola Germania 11

- **Concert viola**
- **Conception: Master luthier Marko Ackert**
- **„Made in Germany“**
- **Production in workshop of GEWA Adorf**
- Selected Bosnian Sycamore Maple
- Manufactured and calibrated for the best possible sound, selected Spruce top
- Open-pore hand varnish, spirit-based
- **Very good response thanks to thin varnish layer**
- Ebony fingerboard and pegs
- **Delivered set-up upon request**

NEW

NEW



GS401.870	Model Berlin Antik 39,5 cm		GS401.890	Model Prag Antik 39,5 cm	
GS401.870.100	Model Berlin Antik 39,5 cm	Set-up	GS401.890.100	Model Prag Antik 39,5 cm	set-up
GS401.871	Model Berlin Antik 40,8 cm		GS401.891	Model Prag Antik 40,8 cm	
GS401.871.100	Model Berlin Antik 40,8 cm	Set-up	GS401.891.100	Model Prag Antik 40,8 cm	set-up
GS401.872	Model Berlin Antik 42,0 cm		GS401.892	Model Prag Antik 42,0 cm	
GS401.872.100	Model Berlin Antik 42,0 cm	Set-up	GS401.892.100	Model Prag Antik 42,0 cm	set-up

NEW

NEW



GS401.880	Model Rom Antik 39,5 cm		GS401.900	Model Paris Antik 39,5 cm	
GS401.880.100	Model Rom Antik 39,5 cm	set-up	GS401.900.100	Model Paris Antik 39,5 cm	set-up
GS401.881	Model Rom Antik 40,8 cm		GS401.901	Model Paris Antik 40,8 cm	
GS401.881.100	Model Rom Antik 40,8 cm	set-up	GS401.901.100	Model Paris Antik 40,8 cm	set-up
GS401.882	Model Rom Antik 42,0 cm		GS401.902	Model Paris Antik 42,0 cm	
GS401.882.100	Model Rom Antik 42,0 cm	set-up	GS401.902.100	Model Paris Antik 42,0 cm	set-up

GEWA Strings

GEWA Concert viola Georg Walther

- **Master Viola**
- **Created by: Meister Marko Ackert**
- **„Made in Germany“**
- Hand selected, beautifully flamed sycamore maple back
- Manufactured and calibrated for the best possible sound, selected spruce top
- Finly selected European tonewood
- Beautifully flamed back
- **Red brown** natural resin varnish, lightly shaded
- Hand varnished
- Inserted purfling
- Ebony fingerboard and pegs
- **Hand-made in our GEWA master workshops**



GS401.932	39,5 cm	
GS401.932.100	39,5 cm	Set-up
GS401.933	40,8 cm	
GS401.933.100	40,8 cm	Set-up
GS401.934	42,0 cm	
GS401.934.100	42,0 cm	Set-up

GEWA Concert viola Georg Walther

- **Master Viola**
- **Created by: Meister Marko Ackert**
- **„Made in Germany“**
- Hand selected, nicely flamed sycamore maple back
- Manufactured and calibrated for the best possible sound, selected spruce top
- fine, selected European tonewood
- **Gold brown** natural resin varnish, lightly shaded
- **Antique hand-varnish**
- Inserted purfling
- Ebony fingerboard and pegs
- **Hand-made in our GEWA master workshops**



GS401.950	42,0 cm	
GS401.950.100	42,0 cm	Set-up
GS401.951	40,8 cm	
GS401.951.100	40,8 cm	Set-up
GS401.952	39,5 cm	
GS401.952.100	39,5 cm	Set-up

GEWA Strings

GEWAPURE Viola outfit HW

- **Hardwood fittings**
- Back and sides solid Maple
- Solid Spruce top
- Inserted purfling
- Dark red-brown varnish
- Chin rest
- Fine tuning tailpiece
- Massaranduba bow with ebony frog
- Rosin
- Light case with screw-attached cover, attached music sheet pocket
- Carrying strap
- incl. all parts
- Set-up



PS402.211*	33,0 cm
PS402.212*	35,5 cm
PS402.213*	38,2 cm
PS402.214*	39,5 cm
PS402.215*	40,8 cm
PS402.216*	42,0 cm

GEWAPURE Viola outfit EW

- **Ebony fittings**
- Back and sides solid Maple
- Solid Spruce top
- Inserted purfling
- Dark red-brown varnish
- Chin rest
- Fine tuning tailpiece
- Massaranduba bow with ebony frog
- Rosin
- **Black light-weight case with screw attached cover and sewn-on music sheet pocket**
- Carrying strap
- Incl. all parts
- Set-up



PS402.221*	33,0 cm
PS402.222*	35,5 cm
PS402.223*	38,2 cm
PS402.224*	39,5 cm
PS402.225*	40,8 cm
PS402.226*	42,0 cm

MODULAR SYSTEM ALLEGRO-VC1

NEW

„Over the last years GEWA has set up a production for bowed instruments. A specifically devised operational and organisational structure as well as state-of-the-art, computerised CNC machines provide the basis for this manufacture that sets a new standard worldwide; processing, preparation and precision live up to the highest demands for every instrument. In addition, only European tonewood is being used, ensuring outstanding sound characteristics in its quality.

Skilled luthiers apply a hand varnish to the perfect “white instrument” that up to now has not been existing in this price range. All features of this extraordinary instrument series result in a sound reproduction that redefines this price segment.“

signed: Marko Ackert (Master Luthier)

The cello Allegro-VC1 is available as **basic instrument**, equipped with **soundpost**, pre-adjusted **bridge** and **upper nut** as well as **fingerboard**, **pegs** and **chin rest** made of ebony (Art-Nr. GS402.051.000.0).

The colour code in the price table relates to the chosen options at delivery

not set up
 safe for transport (bridge and soundpost down for safe transport)
 set up

The basic model can be fitted suiting individual demands (see table).



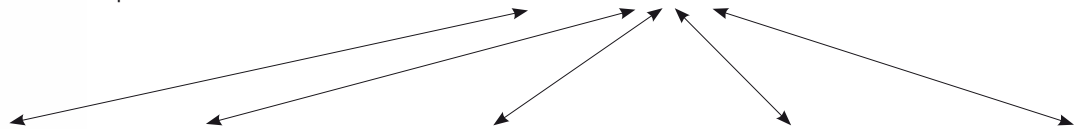

To determine the required configuration of the cello / cello outfits the following options are available – please add the respective figures.

Example item number:

GS402.051. 2 1 1 . 1



**Cello 4/4
(Basic-instrument)**

Deivered as	Bag	Bow	Strings incl. tailpiece
0 Not set up	0 without bag	0 without bow	0 without strings and tailpiece
1 Safe for transport <i>(bridge and soundpost down for safe transport)</i> incl. • Ebony fittings • Original Aubert bridge • Wittner fine tuning tailpiece • Thomastik-Infeld AlphaYue strings • End pin	1 with bag 	1 with Massaranduba bow 	1 with Thomastik Infeld Alphayue strings / Larsen Crown strings incl. Wittner tailpiece 
2 Set up incl. • Ebony fittings • Original Aubert bridge • Wittner fine tuning tailpiece • Thomastik-Infeld AlphaYue strings • End pin		2 with carbon bow 	

GEWA Cello Allegro-VC1

- Back and sides made of **solid EUROPEAN MAPLE**
- Solid **EUROPEAN SPRUCE TOP**
- **Brown-amber coloured natural resin varnish**
- Inserted purfling
- Ebony fittings
- **Original Aubert bridge, pre-adjusted**
- **Wittner fine tuning tailpiece** (optional; see above)
- **Thomastik-Infeld AlphaYue / Larsen Crown strings** (optional; see above)
- End pin
- Rosin (optional, see above)
- Massaranduba / Carbon bow with natural hair (optional; see above)
- Cello bag with bow and string pocket and rucksack straps (optional; see above)
- Minimal colour variation possible due to hand-varnished treatment
- **Not set up: without label**; all other options without label
- If generally „without label“, please inform



GS402.051.000.0	4/4	without setup, with pre-adjusted bridge
GS402.051.010.0	4/4	without setup, with pre-adjusted bridge, incl. bag
GS402.051.100.1	4/4	with set up
GS402.051.111.1	4/4	Setup incl. bag, Massaranduba bow, Larsen Crown strings
GS402.051.112.1	4/4	Setup, incl. bag, carbon bow, Larsen Crown strings
GS402.051.200.1	4/4	with set up
GS402.051.211.1	4/4	TOPSELLER Setup, incl. bag, Massaranduba bow, Crown strings
GS402.051.212.1	4/4	Setup, incl. bag, carbon bow, Crown strings

GS402.052.000.0	3/4	without setup, with pre-adjusted bridge
GS402.052.010.0	3/4	without setup, pre-adjusted bridge incl. bag
GS402.052.100.1	3/4	with set up
GS402.052.111.1	3/4	Setup incl. bag, Massaranduba bow, Thomastik-Infeld AlphaYue / Larsen Crown strings
GS402.052.112.1	3/4	Setup, incl. bag, carbon bow, Thomastik-Infeld AlphaYue / Crown strings
GS402.052.200.1	3/4	with set up
GS402.052.211.1	3/4	TOPSELLER Setup, incl. bag, Massaranduba bow, Thomastik-Infeld AlphaYue / Larsen Crown strings
GS402.052.212.1	3/4	Setup, incl. bag, carbon bow, Thomastik-Infeld AlphaYue / Larsen Crown strings

GS402.053.000.0	1/2	without setup, with pre-adjusted bridge
GS402.053.010.0	1/2	without setup, pre-adjusted bridge incl. bag
GS402.053.100.1	1/2	with set up
GS402.053.111.1	1/2	Setup incl. bag, Massaranduba bow, Thomastik-Infeld AlphaYue / Larsen Crown strings
GS402.053.112.1	1/2	Setup, incl. bag, carbon bow, Thomastik-Infeld AlphaYue / Larsen Crown strings
GS402.053.200.1	1/2	with set up
GS402.053.211.1	1/2	TOPSELLER Setup, incl. bag, Massaranduba bow, Thomastik-Infeld AlphaYue / Larsen Crown strings
GS402.053.212.1	1/2	Setup, incl. bag, carbon bow, Thomastik-Infeld AlphaYue / Larsen Crown strings

GS402.054.000.0	1/4	without setup, with pre-adjusted bridge
GS402.054.010.0	1/4	without setup, with pre-adjusted bridge, incl. bag
GS402.054.100.1	1/4	with set up
GS402.054.111.1	1/4	Setup incl. bag, Massaranduba bow, Thomastik-Infeld AlphaYue / Larsen Crown strings
GS402.054.112.1	1/4	Setup, incl. bag, carbon bow, Thomastik-Infeld AlphaYue / Larsen Crown strings
GS402.054.200.1	1/4	with set up
GS402.054.211.1	1/4	TOPSELLER Setup, incl. bag, Massaranduba bow, Thomastik-Infeld AlphaYue / Larsen Crown strings
GS402.054.212.1	1/4	Setup, incl. bag, carbon bow, Thomastik-Infeld AlphaYue / Larsen Crown strings

MODULAR SYSTEM IDEALE-VC2

NEW

„Over the last years GEWA has set up a production for bowed instruments. A specifically devised operational and organisational structure as well as state-of-the-art, computerised CNC machines provide the basis for this manufacture that sets a new standard worldwide; processing, preparation and precision live up to the highest demands for every instrument. In addition, only European tonewood is being used, ensuring outstanding sound characteristics in its quality.

Skilled luthiers apply a hand varnish to the perfect “white instrument” that up to now has not been existing in this price range. All features of this extraordinary instrument series result in a sound reproduction that redefines this price segment.“

signed: Marko Ackert (Master Luthier)

The cello Ideale-VC2 is available as **basic instrument**, equipped with **soundpost**, pre-adjusted **bridge** and **upper nut** as well as **fingerboard**, **pegs** and **chin rest** made of ebony (Art-Nr. GS402.061.000.0).

The colour code in the price table relates to the chosen options at delivery

not set up
 safe for transport (bridge and soundpost down for safe transport)
 set up





The basic model can be fitted suiting individual demands (see table). To determine the required configuration of the cello / cello outfits the following options are available – please add the respective figures.

Example item number:

GS402.061. 2 1 1 . 1



**Cello 4/4
(Basic-instrument)
GS402.061.**

Deivered as	Bag	Bow	Strings incl. tailpiece
0 Not set up	0 without bag	0 without bow	0 without strings and tailpiece
1 Safe for transport <i>(bridge and soundpost down for safe transport)</i> incl. • Ebony fittings • Original Aubert bridge • Wittner fine tuning tailpiece • Thomastik-Infeld AlphaYue strings • End pin	1 with bag 	1 with Massaranduba bow 	1 with Thomastik Infeld Alphayue strings / Larsen Crown strings incl. Wittner tailpiece 
2 Set up incl. • Ebony fittings • Original Aubert bridge • Wittner fine tuning tailpiece • Thomastik-Infeld AlphaYue strings • End pin		2 with carbon bow 	

GEWA Cello Ideale-VC2

- Back and sides made of **solid EUROPEAN MAPLE**
- Solid **EUROPEAN SPRUCE TOP**
- **Red-brown natural resin varnish**
- **Hand varnish**
- Inserted purfling
- Ebony fittings
- **Original Aubert bridge, pre-adjusted**
- **Wittner fine tuning tailpiece** (optional; see above)
- **Thomastik-Infeld AlphaYue / Larsen Crown strings** (optional; see above)
- End pin
- Rosin (optional, see above)
- Massaranduba / Carbon bow with natural hair (optional; see above)
- Cello bag with bow and string pocket and rucksack straps (optional; see above)
- Minimal colour variation possible due to hand-varnished treatment
- **Not set up: without label;** all other options including label
- If generally „without label“, please inform



GS402.061.000.0	4/4	without setup, with pre-adjusted bridge
GS402.061.010.0	4/4	without setup, pre-adjusted bridge incl. bag
GS402.061.100.1	4/4	with set up
GS402.061.111.1	4/4	Setup, incl. bag, Massaranduba bow, Thomastik-Infeld AlphaYue / Larsen Crown strings
GS402.061.112.1	4/4	Setup, incl. bag, carbon bow, Thomastik-Infeld AlphaYue / Larsen Crown strings
GS402.061.200.1	4/4	with set up
GS402.061.211.1	4/4 TOPSELLER	Setup, incl. bag, Massaranduba bow, Thomastik-Infeld AlphaYue / Larsen Crown strings
GS402.061.212.1	4/4	Setup, incl. bag, carbon bow, Thomastik-Infeld AlphaYue / Larsen Crown strings

GS402.062.000.0	3/4	without setup, with pre-adjusted bridge
GS402.062.010.0	3/4	without setup, pre-adjusted bridge incl. bag
GS402.062.100.1	3/4	with set up
GS402.062.111.1	3/4	Setup, incl. bag, Massaranduba bow, Thomastik-Infeld AlphaYue / Larsen Crown strings
GS402.062.112.1	3/4	Setup, incl. bag, carbon bow, Thomastik-Infeld AlphaYue / Larsen Crown strings
GS402.062.200.1	3/4	with set up
GS402.062.211.1	3/4 TOPSELLER	Setup, incl. bag, Massaranduba bow, Thomastik-Infeld AlphaYue / Larsen Crown strings
GS402.062.212.1	3/4	Setup, incl. bag, carbon bow, Thomastik-Infeld AlphaYue / Larsen Crown strings

GS402.063.000.0	1/2	without setup, with pre-adjusted bridge
GS402.063.010.0	1/2	without setup, pre-adjusted bridge incl. bag
GS402.063.100.1	1/2	with set up
GS402.063.111.1	1/2	Setup, incl. bag, Massaranduba bow, Thomastik-Infeld AlphaYue / Larsen Crown strings
GS402.063.112.1	1/2	Setup, incl. bag, carbon bow, Thomastik-Infeld AlphaYue / Larsen Crown strings
GS402.063.200.1	1/2	with set up
GS402.063.211.1	1/2 TOPSELLER	Setup, incl. bag, Massaranduba bow, Thomastik-Infeld AlphaYue / Larsen Crown strings
GS402.063.212.1	1/2	Setup, incl. bag, carbon bow, Thomastik-Infeld AlphaYue / Larsen Crown strings

GS402.064.000.0	1/4	without setup, with pre-adjusted bridge
GS402.064.010.0	1/4	without setup, with pre-adjusted bridge, incl. bag
GS402.064.100.1	1/4	with set up
GS402.064.111.1	1/4	Setup, incl. bag, Massaranduba bow, Thomastik-Infeld AlphaYue / Larsen Crown strings
GS402.064.112.1	1/4	Setup, incl. bag, carbon bow, Thomastik-Infeld AlphaYue / Larsen Crown strings
GS402.064.200.1	1/4	with set up
GS402.064.211.1	1/4 TOPSELLER	Setup, incl. bag, Massaranduba bow, Thomastik-Infeld AlphaYue / Larsen Crown strings
GS402.064.212.1	1/4	Setup, incl. bag, carbon bow, Thomastik-Infeld AlphaYue / Larsen Crown strings

GEWA Strings

GEWA Cello Maestro 6

- **Advanced Student Cello**
- Back and sides made of solid Maple
- Solid Spruce top
- Better flamed back
- Maroon natural resin varnish, slightly shaded
- Inserted purfling
- Ebony fingerboard and pegs



GS402.370	4/4	
GS402.370.100	4/4	Set-up
GS402.371	7/8	
GS402.371.100	7/8	Set-up
GS402.372	3/4	
GS402.372.100	3/4	Set-up
GS402.373	1/2	
GS402.373.100	1/2	Set-up
GS402.374	1/4	
GS402.374.100	1/4	Set-up
GS402.375	1/8	
GS402.375.100	1/8	Set-up
GS402.376	1/16	
GS402.376.100	1/16	Set-up

GS402.381	4/4 Antique	
GS402.381.100	4/4 Antique	Set-up
GS402.382	3/4 Antique	
GS402.382.100	3/4 Antique	Set-up



NEW

GS402.370.51	4/4 LEFTHAND	
GS402.370.51.100	4/4 LEFTHAND	Set-up

GEWA Strings

GEWA Cello Maestro 24

- **Advanced Student Cello**
- **French Style**
- Back and sides made of solid Maple
- Solid spruce top with fine grains
- Beautiful, deep flamed back
- Transparent maroon natural resin varnish, strongly shaded
- Antique hand-varnish
- Inserted purfling
- Ebony fingerboard and pegs



GS402.418	4/4	
GS402.418.100	4/4	Set-up
GS402.419	3/4	
GS402.419.100	3/4	Set-up
GS402.420	1/2	
GS402.420.100	1/2	Set-up

GEWA Cello Maestro 31

- **Advanced Student Cello**
- Back and sides made of solid Maple
- Solid spruce top with fine grains
- Beautiful, flamed back
- Dark red brown transparent natural resin varnish, slightly shaded
- Hand varnished
- Inserted purfling
- Ebony fingerboard and pegs



GS402.431	4/4	
GS402.431.100	4/4	Set-up
GS402.432	7/8	
GS402.432.100	7/8	Set-up
GS402.441	4/4 Antique	
GS402.441.100	4/4 Antique	Set-up

GEWA Cello Maestro 26

- **Advanced Student Cello**
- Back and sides solid Maple - **nicely flamed**
- Solid Siberian spruce top with fine annual rings
- Inserted purfling
- Ebony fingerboard and pegs
- Especially hollowed F-holes
- **Spirit hand varnish** - darkbrown / amber colored
- Slightly antique



GS402.426	4/4	
GS402.426.100	4/4	Set-up

GEWA Cello Maestro 46

NEW

- **Advanced Student Cello**
- **German Style**
- Back and sides made of solid Maple
- Solid **German spruce top with fine annual rings**
- **Better flamed European sycamore back**
- Red brown transparent natural resin varnish
- Hand varnished
- Inserted purfling
- Ebony fingerboard and pegs
- Minimal color variation due to hand varnished treatment



GS402.461	4/4	
GS402.461.100	4/4	Set-up

GEWA Strings

GEWA Cello Germania 11

- **Concert Cello**
- **Conception: luthier Marko Ackert**
- **„Made in Germany“**
- **Production in workshop of GEWA Adorf**
- Selected Bosnian sycamore
- Manufactured and calibrated for the best possible sound, selected Spruce top
- Open-pore hand varnish, spirit-based
- **Very good response thanks to thin varnish layer**
- Ebony fingerboard and pegs
- **Delivered set-up upon request**



GS403.010	4/4 Model Berlin antique		GS403.012	4/4 Model Prag antique	
GS403.010.100	4/4 Model Berlin antique	Set-up	GS403.012.100	4/4 Model Prag antique	Set-up
GS403.010.78	7/8 Model Berlin antique		GS403.012.78	7/8 Model Prague antique	
GS403.010.78.100	7/8 Model Berlin antique	Set-up	GS403.012.78.100	7/8 Model Prague antique	Set-up
GS403.020	4/4 Model Berlin		GS403.022	4/4 Model Prague	
GS403.020.100	4/4 model Berlin	Set-up	GS403.022.100	4/4 Model Prague	Set-up
GS403.020.78	7/8 Model Berlin		GS403.022.78	7/8 Model Prague	
GS403.020.78.100	7/8 Model Berlin	Set-up	GS403.022.78.100	7/8 Model Prague	Set-up



GS403.011	4/4 Model Rom antique		GS403.014	4/4 Model Paris antique	
GS403.011.100	4/4 Model Rom antique	Set-up	GS403.014.100	4/4 Model Paris antique	Set-up
GS403.011.78	7/8 Model Rome antique		GS403.014.78	7/8 Model Paris antique	
GS403.011.78.100	7/8 Model Rome antique	Set-up	GS403.014.78.100	7/8 Model Paris antique	Set-up
GS403.021	4/4 Model Rome		GS403.024.100	4/4 Model Paris	Set-up
GS403.021.100	4/4 Model Rome	Set-up	GS403.024.78.100	7/8 Model Paris	Set-up
GS403.021.78	7/8 Model Rome		GS403.024.78	7/8 Model Paris	
GS403.021.78.100	7/8 Model Rome	Set-up	GS403.024	4/4 Model Paris	

GEWA Strings

GEWA Concert cello Georg Walther

- „Made in Germany“
- **Master Cello**
- **Conception: master luthier Marko Ackert**
- **Montagnana-model**
- Hand selected, nicely flamed sycamore back
- Manufactured and calibrated for the best possible sound, selected German spruce top
- Finest, selected European tonewood, highest quality
- Nicely flamed back
- Red brown, slightly shaded varnish
- **Hand varnish**
- Inserted purfling
- Ebony fingerboard and pegs
- **Hand-made in our GEWA master workshops**



GS403.030 4/4
GS403.030.100 4/4 Set-up

GEWA Concert cello Georg Walther

- „Made in Germany“
- **Master Cello**
- **Conception: master luthier Marko Ackert**
- Hand selected, beautifully flamed sycamore back
- Manufactured and calibrated for the best possible sound, selected German spruce top
- Finest, selected European tonewood, highest quality
- Dark red brown natural resin varnish, lightly shaded
- **Antique hand varnish**
- Inserted purfling
- Ebony fingerboard and pegs
- **Hand-made in our GEWA master workshops**



GS403.060 4/4
GS403.060.100 4/4 Set-up

GEWA Concert cello Georg Walther

- „Made in Germany“
- **Master Cello**
- **Conception: master luthier Marko Ackert**
- Hand selected, beautiful flamed Sycamore back
- Manufactured and calibrated for the best possible sound, selected German spruce top
- Finest, selected European tonewood, highest quality
- Gold yellow transparent natural resin varnish
- **Hand varnish**
- Inserted purfling
- Ebony fingerboard and pegs
- **Hand-made in our GEWA master workshops**



GS403.070 4/4
GS403.070.100 4/4 Set-up

GEWA Strings

GEWA Concert cello Meister Rubner

- „Made in Germany“
- **Master Cello**
- **Conception: Master Marko Ackert**
- Hand selected, beautifully flamed sycamore back
- Manufactured and calibrated for the best possible sound, selected German spruce top
- Transparent natural resin varnish
- **Hand varnish**
- Inserted purfling
- Sacconi bridge
- Thomastik-Infeld Versum strings
- High quality fittings of ebony/boxwood
- **Hand-made in our GEWA master workshops in old Rubner tradition**
- **Delivered set-up**



GS403.080.100	4/4	Dark red
GS403.085.100	4/4	Amber coloured

GEWA Strings

GEWAPURE Cello outfit HW

- Hard wood fitting
- Solid spruce top, solid maple back
- Inserted purfling
- Dark red-brown varnish
- Fine tuning tailpiece
- Steel strings
- Endpin with ebony cone
- Bow with natural hair
- Cello bag made of Nytex
- Bow and string pocket
- incl. all parts
- Set-up



PS403.211* 4/4

PS403.212* 3/4

PS403.213* 1/2

PS403.214* 1/4

PS403.215* 1/8

GEWAPURE Cello outfit EW

- Ebony fittings
- Solid spruce top, solid maple back
- Inserted purfling
- Dark red-brown varnish
- Fine tuning tailpiece
- Steel strings
- Endpin with ebony cone
- Bow with natural hair
- Cello bag made of Nytex
- Bow and string pocket
- incl. all parts
- Set-up



PS403.221* 4/4

PS403.222* 3/4

PS403.223* 1/2

PS403.224* 1/4

PS403.225* 1/8

GEWA Strings

GEWA Double bass Basic Line Laminated version

- Gamba shape
- **Laminated top, back and sides**
- Machine head Tyrolean shape
- Ebony fingerboard
- Golden brown finish
- **Set up in GEWA master workshops**



GS403.301	4/4
GS403.302	3/4
GS403.303	1/2
GS403.304	1/4
GS403.305	1/8
GS403.306	1/16

Fits into a 4/4 cello bag

GEWA Strings

GEWA Double bass Basic Line Solid top version

- Gamba shape
- **Solid Spruce top**
- Back and sides laminated
- Inserted purfling
- Machine head Tyrolean shape, brass
- Ebony fingerboard
- Golden brown finish
- **Set-up done in GEWA master workshops**



GS403.311	4/4	
GS403.312	3/4	
GS403.312.501	3/4	Lefthand
GS403.313	1/2	
GS403.314	1/4	
GS403.315	1/8	

GEWA Strings

GEWA Double bass Basic Line All solid version

- Violin shape
- **Solid Spruce top**
- **Solid Maple back**
- Inserted purfling
- **Rubner machine head**, Tyrolean brass shape
- Ebony fingerboard
- Reddish brown spirit varnish, shaded
- **Set-up in GEWA master workshops**



GS403.321	4/4
GS403.322	3/4
GS403.323	1/2
GS403.324	1/4

GEWA Strings

GEWA Double bass Premium Line Laminated version

- Violin shape
- **Laminated top, back and sides**
- Inserted purfling
- Single machine head brass
- Ebony fingerboard
- Dark brown hand varnish, slightly antique
- **Set up in GEWA master workshops**



GEWA Strings

GEWA Double bass Premium Line Solid top version

- Violin shape
- **Solid Spruce top**
- Back and sides laminated
- Inserted purfling
- Single machine head brass
- Ebony fingerboard
- Dark brown hand varnish, slightly antique
- **Set up in GEWA master workshops**



GS403.341	4/4
GS403.342	3/4
GS403.343	1/2
GS403.344	1/4

GEWA Strings

GEWA Double bass Premium Line All solid version

- Violin shape
- **Solid Spruce top**
- **Solid Maple back and solid side**
- Inserted purfling
- Single machine head brass
- Ebony fingerboard
- **Dark brown hand varnish, slightly antique – very good response**
- Set up in GEWA master workshops



GEWA Strings

GEWA Double bass Europe

- **All solid version**
- Gamba shape
- **Solid Spruce top**
- **Solid Maple back and solid side**
- Inserted purfling
- Machine head Tyrolean shape, nickel plated
- Ebony fingerboard
- Red-brown varnish, shadowed, semi gloss
- Nuremberger precision strings
- **Set up in GEWA master workshops**



GS403.683 3/4

GEWA Strings

GEWA Double bass Rockabilly

- Gamba shape
- **Laminated spruce top**
- **Arched, laminated maple back**
- Tyrolean machine heads
- **Wider Ebony fingerboard**
- Fingerboard markings / Dots as indication
- **Satin black finish**
- Nuremberger precision strings
- Special strings upon request possible
- Bridge height adjustable
- Pickups from our range as additional option possible
- **Set up in GEWA master workshops**



GS403.684 3/4

- Special Feature / German set-up with:
- Bridge height adjustable
- Wider fingerboards
- Fingerboard markings / Dots as indications
- **Shadow pickup RB-Pro Rockabilly PU/EQ/Preamp**
- Developed with Didi Beck
- **2 pickups (bridge/neck)**
- Pyramid Black Tape Nylon Wound Strings

GS403.684.100 3/4

GEWA Strings

GEWA Double bass Germania 11

- Gamba shape
- „Made in Germany“
- Production: Workshops GEWA Adorf
- **Development and conception: GEWA Adorf / double bass master Marko Ackert**
- Selected Bosnian sycamore maple
- Manufactured and calibrated for the best possible sound, selected Spruce top
- **Open-pore hand varnish, spirit-based**
- **Very good response thanks to thin varnish layer**
- Ebony fingerboard
- Rubner single machine head
- Corelli strings
- **Delivered set-up**



GS403.750	Model Berlin antique 3/4
GS403.750.120	Model Berlin antique 1/2
GS403.750.580	Model Berlin antique 5/8

GEWA Strings

GEWA Double bass Germania 11

- Gamba shape
- „**Made in Germany**“
- Production: Workshops GEWA Adorf
- **Development and conception:**
GEWA Adorf / double bass master Marko Ackert
- Selected Bosnian sycamore maple
- Manufactured and calibrated for the best possible sound, selected Spruce top
- **Open-pore hand varnish, spirit-based**
- **Very good response thanks to thin varnish layer**
- Ebony fingerboard
- Rubner single machine head
- Corelli strings
- **Delivered set-up**



GS403.751	Model Rom antique 3/4
GS403.751.120	Model Rom antique 1/2
GS403.751.580	Model Rom antique 5/8

GEWA Strings

GEWAPURE Double bass LW

- Laminated
- Arched back
- Hard wood fittings
- Tyrolean machine heads
- Dark red-brown varnish
- incl. all parts
- Set-up



PS403.501*	4/4
PS403.502*	3/4
PS403.503*	1/2
PS403.504*	1/4
PS403.505*	1/8

GEWAPURE Double bass ST

- **Solid Spruce top**
- Arched, laminated back
- Flamed back
- Flamed, laminated sides
- Ebony fingerboard
- **Single machine head / Tyrolean machine head**
- Dark red-brown varnish
- incl. all parts
- Set-up



PS403.606*	4/4
PS403.607*	3/4
PS403.608*	1/2
PS403.609*	1/4
PS403.610*	1/8
PS403.611*	1/16

GEWA Strings

GEWA Double bass MEISTER MICHAEL GLASS Model No. 5

- Concert instrument
- **All solid version**
- Gamba shape
- Solid German Spruce top
- Solid flat back
- Inserted purfling
- Rubner machine heads, Tyrolean shape, brass
- Ebony fingerboard
- Maroon spirit hand varnish
- Thomastik Belcanto strings
- D-scale 104,5 cm
- **Delivered set-up**



GS403.713 3/4

GEWA Strings

GEWA Double bass MEISTER MICHAEL GLASS Model Nr. 10

- Concert instrument
- **All solid version**
- Gamba shape
- Solid German Spruce top
- Solid arched maple back
- Rib with cornice
- Inserted purfling
- Rubner machine heads, Tyrolean shape, brass
- Ebony fingerboard
- Red brown spirit lacquer, hand varnished
- Thomastik Belcanto strings
- D-scale 104,5 cm
- **Delivered set-up**



GS403.720 4/4
GS403.721 3/4

GEWA Strings

GEWA Double bass MEISTER MICHAEL GLASS Model Nr. 20

- Master instrument
- **All solid version**
- Gamba shape
- Solid German Spruce top with fine annual rings
- Solid, flamed Maple back, arched
- Rib with cornice
- Inserted purfling
- Rubner machine heads french form, brass
- Ebony fingerboard
- Red brown spirit lacquer, hand varnished
- Thomastik Belcanto strings
- D-scale 104,5 cm
- **Delivered set-up**



GS403.810	4/4
GS403.811	3/4
GS403.820	4/4 5-string

GEWA Strings

GEWA Double bass MEISTER MICHAEL GLASS Model Nr. 30

- Soloist instrument
- **All solid version**
- Violin shaped, italian model
- Solid German Spruce top with fine annual rings
- Solid flat back, flamed
- Inserted purfling
- Rubner machine heads, french form, brass
- Ebony fingerboard
- Red brown spirit lacquer, hand varnished
- Thomastik Belcanto strings
- D-scale 104,5 cm
- **Delivered set-up**



GS403.830 3/4

GS403.840 4/4 5-string

GEWA Strings

GEWA Double bass MEISTER RUBNER Model Nr. 62

- Artists instrument
- **All solid version**
- Gamba shape
- Solid German Spruce top
- Solid arched maple back
- Inserted purfling
- Rubner single machine heads, brass engraved
- Ebony fingerboard
- Golden-brown spirit hand varnish
- Thomastik Belcanto strings
- D-scale 104,5 cm
- **Delivered set-up**



GS403.900	3/4
GS403.901	4/4
GS403.902	4/4 5-string

GEWA Strings

GEWA Double bass MEISTER RUBNER Model No. 66

- Concert instrument
- **All solid version**
- Violin shape
- Solid selected German Spruce top
- Solid arched poplar back
- Rib made out of poplar
- Inserted purfling
- Rubner single machine heads, brass engraved
- Ebony fingerboard
- Golden-brown spirit hand varnish
- Thomastik Belcanto strings
- D-scale 104,5 cm
- **Delivered set-up**



GS403.940 3/4
GS403.941 4/4

GEWA Strings

GEWA Double bass MEISTER RUBNER Model No. 67

- Artists instrument
- **All solid version**
- Gamba shape
- Solid, selected German Spruce top with fine annual rings
- Solid, flamed Maple back, arched
- **Double inserted purfling**
- **Rubner machine heads french form, brass**
- Ebony fingerboard
- Golden-brown spirit hand varnish
- Thomastik Belcanto strings
- D-scale 104,5 cm
- **Delivered set-up**



GS403.950	3/4
GS403.951	4/4
GS403.952	4/4 5-string

GEWA Strings

GEWA Double bass MEISTER RUBNER Model No. 68B

- Artists instrument
- **All solid version**
- Model Busseto
- Solid, selected German Spruce top with fine annual rings
- Solid, flamed Maple back, arched
- Inserted purfling
- Rubner single machine head, brass, engraved with Ebony pegs
- Ebony fingerboard
- Dark red-brown open pore antique hand varnish
- Thomastik Belcanto strings
- D-scale 104,5 cm
- **Delivered set-up**



GS403.960 3/4
GS403.961 4/4

GEWA Strings

GEWA Double bass MEISTER RUBNER Model No. 68 M

- Soloist instrument
- **All solid version**
- Violin shaped, Montagnana-model
- Solid, selected German Spruce top with fine annual rings
- Solid, flamed Maple back, arched
- Inserted purfling
- Rubner machine heads, french form, antique
- Ebony fingerboard
- Dark red-brown antique hand varnish
- Thomastik Belcanto strings
- D-scale 104,5 cm
- **Delivered set-up**



GS403.965	4/4
GS403.966	4/4 5-string

GEWA Strings

GEWA Double bass MEISTER RUBNER MODEL No. 69

- Soloist instrument
- **All solid version**
- Gamba shape
- Solid, selected German Spruce top with fine annual rings
- Solid, very beautiful flamed maple back, arched
- Double inserted purfling and hand-cut ornamental edging on top and back
- Rubner single machine head, brass, engraved with Ebony pegs
- Ebony fingerboard
- Golden brown spirit hand varnish, semi gloss
- Thomastik Belcanto strings
- D-scale 104,5 cm
- **Delivered set-up**



GS403.970	3/4
GS403.971	4/4
GS403.972	4/4 5-string

GEWA Strings

GEWA Violin bow Massaranduba Student

- Ebony frog
- Natural hair
- Good quality
- Round stick



404.011	4/4
404.012	3/4
404.013	1/2
404.014	1/4
404.015	1/8
404.016	1/16

- Better quality
- Octagonal stick



404.031	4/4	Pcs.assort.+
404.032	3/4	Pcs.assort.+
404.033	1/2	Pcs.assort.+
404.034	1/4	Pcs.assort.+
404.035	1/8	Pcs.assort.+
404.036	1/16	Pcs.assort.+

- Selected quality
- Octagonal stick



404.051	4/4
404.052	3/4
404.053	1/2
404.054	1/4
404.055	1/8
404.056	1/16

GEWA Violin bow Massaranduba

- Whalebone wrapping
- Ebony frog with slide
- Natural hair
- Parisian eye
- Octagonal stick
- Nickel silver button



404.041	4/4
404.042	3/4
404.043	1/2
404.044	1/4
404.045	1/8
404.046	1/16

- Ebony frog
- Natural hair
- Good quality
- Round stick
- stamped „Jaeger“



404.071	4/4
404.072	3/4
404.073	1/2
404.074	1/4
404.075	1/8
404.076	1/16

- Better quality
- Octagonal stick
- stamped „Jaeger“



404.081	4/4
404.082	3/4
404.083	1/2
404.084	1/4

- Selected quality
- Octagonal stick
- stamped „Jaeger“



404.091	4/4
404.092	3/4
404.093	1/2

- Ebony frog with Parisian eyelet
- Natural hair
- Selected quality
- Octagonal stick
- Stamped "Atelier Jaeger"



404.101	4/4
404.102	3/4
404.103	1/2

GEWA Violin bow H.Walter Zapf Pernambuco wood

- Nickel silver with stamp



404.106	Octagonal
---------	-----------

GEWA Strings

GEWA Violin bow H.Walter Zapf Pernambuco wood

- Ebony frog
- Natural hair
- Good quality
- Octagonal stick



404.111	4/4
404.112	3/4
404.113	1/2

- Better quality
- Round stick



404.121	4/4
404.122	3/4

- Selected quality
- Round stick



404.131	4/4
---------	-----

- Ebony frog with Parisian eyelet
- Ebony slide with mother-of-pearl
- Silver screw
- Good quality
- Octagonal stick
- Stamped "Atelier Jaeger"



404.135	4/4
---------	-----

- **Liuteria Maestro**
- Pernambuco bow 4/4-Size
- Fishbone (imitation) winding with short thumb leather
- Ebony frog with Parisian eyelet
- Ebony slide with mother-of-pearl
- Three part silver leg with artistic dot/cross inlays and mother-of-pearl eyelet
- Silver screw
- **Stamped „Manufactum“**
- Good quality



404.141	4/4 Round
404.142	4/4 Octagonal

- Better quality



404.145	Round
404.146	Octagonal

GEWA Violin bow Franz Bergner

- Nickel silver with stamp



404.151	Round
404.152	Octagonal

GEWA Violin bow Erwin Mahler

- Nickel silver with stamp



404.173	Round
404.174	Octagonal

GEWA Violin bow Gérard Moulin

- Nickel silver with stamp



404.175	Round
404.176	Octagonal

GEWA Violin bow Robert Reichel

- Nickel silver with stamp



404.181	Round
404.182	Octagonal

GEWA Violin bow Peter Stenzel

- Nickel silver with stamp



404.187	Round
404.188	Octagonal

GEWA Strings

GEWA Violin bow W.R. Wild

- Nickel silver with stamp



404.191	Round
404.192	Octagonal

GEWA Violin bow Robert Reichel

- Silver with stamp



404.251	Round
404.252	Octagonal

W. E. DÖRFLER Violin bow

- Silver with stamp



404.215	Round
404.216	Octagonal

GEWA Violin bow W.R. Wild

- Silver with stamp



404.281	Round
404.282	Octagonal

W. E. DÖRFLER Violin bow

- Ligne Bohème
- Round premium pernambuco stick
- Sartory head
- Ebony frog
- Parisian eye
- 3-piece. leg
- Goldfish inlay
- Silver with „Egidius Dörfler“ stamp



404.217	Round
---------	-------

GEWA Violin bow Carbon Jeki

- Nickel silver
- Ebony frog with slide
- Natural hair
- Parisian eye



404.290	4/4
404.291	3/4
404.292	1/2
404.293	1/4
404.294	1/8
404.295	1/16

OTTO DÜRRSCHMIDT Violin bow

- Silver with stamp
- Very well-chosen stick
- Ebony frog with Parisian eyelet
- Eye with silver ring
- **GEWA exclusive model**



404.223	Round
404.224	Octagonal

GEWA Violin bow Carbon

- Round stick
- Ebony frog with back plate
- Parisian eyelet
- Natural hair



404.299	4/4 Violins
---------	-------------

GEWA Violin bow Carbon

- Round stick
- Ebony frog with Parisian eyelet
- Nickel silver tapping
- Natural hair



404.231	Round
404.232	Octagonal



404.300	4/4
---------	-----

GEWA Strings

GEWA Viola bow Massaranduba Student

- Ebony frog
- Natural hair
- Good quality
- Round stick



404.301 4/4
404.302 3/4
404.303 1/2

- Selected quality
- Octagonal stick



404.311 4/4

- Better quality
- Octagonal stick



404.315 4/4

- Ebony frog
- Natural hair
- Good quality
- Round stick
- stamped „Jaeger“



404.331 4/4
404.332 3/4
404.333 1/2

- Better quality
- Octagonal stick
- stamped „Jaeger“



404.341 4/4

- Selected quality
- Octagonal stick
- stamped „Jaeger“



404.345 4/4

- Ebony frog with Parisian eyelet
- Natural hair
- Selected quality
- Octagonal stick
- Stamped „Atelier Jaeger“



404.350 4/4

- Ebony frog
- Natural hair
- Good quality
- Octagonal stick



404.361 4/4 Pcs.assort.+

- Selected quality
- Round stick



404.371 4/4

- **Liuteria Maestro**
- Pernambuco bow 4/4-Size
- Fishbone (imitation) winding with short thumb leather
- Ebony frog with Parisian eyelet
- Ebony slide with mother-of-pearl
- Three part silver leg with artistic dot / cross inlays
- Silver screw
- **Stamped „Liuteria“**
- Good quality



404.375 Round

404.376 Octagonal

- Better quality



404.381 Round

404.382 Octagonal

GEWA Viola bow Franz Bergner

- Nickel silver with stamp



404.401 Round

404.402 Octagonal

GEWA Strings

GEWA Viola bow Erwin Mahler

- Nickel silver with stamp



404.423	Round
404.424	Octagonal

GEWA Viola bow W.R. Wild

- Nickel silver with stamp



404.441	Round
404.442	Octagonal

GEWA Viola bow Carbon

- Nickel silver
- Ebony frog with slide
- Natural hair
- Parisian eye



404.547	4/4
404.547.501	3/4
404.547.502	1/2

GEWA Cello bow Massaranduba Student

- Ebony frog
- Natural hair
- Good quality
- Round stick



404.551	4/4	Pcs.assort.+
404.552	3/4	Pcs.assort.+
404.553	1/2	Pcs.assort.+
404.554	1/4	Pcs.assort.+
404.555	1/8	Pcs.assort.+

- Better quality
- Octagonal stick



404.561	4/4	Pcs.assort.+
404.562	3/4	Pcs.assort.+
404.563	1/2	Pcs.assort.+
404.564	1/4	Pcs.assort.+
404.565	1/8	Pcs.assort.+

- Selected quality
- Octagonal stick



404.571	4/4	Pcs.assort.+
404.572	3/4	Pcs.assort.+
404.573	1/2	Pcs.assort.+
404.574	1/4	Pcs.assort.+

- Ebony frog
- Natural hair
- Good quality
- Round stick
- stamped „Jaeger“



404.591	4/4
404.592	3/4
404.593	1/2
404.594	1/4
404.595	1/8

- Better quality
- Octagonal stick
- stamped „Jaeger“



404.601	4/4
404.602	3/4
404.603	1/2
404.604	1/4

- Selected quality
- Octagonal stick
- stamped „Jaeger“



404.611	4/4
404.612	3/4
404.613	1/2

- Student bow
- Ebony frog with Parisian eyelet
- Natural hair
- Selected quality
- Octagonal stick
- Stamped "Atelier Jaeger"



404.614	4/4
404.614.501	3/4
404.614.502	1/2

GEWA Strings

GEWA Cello bow Massaranduba Student

- Ebony frog
- Natural hair
- Good quality
- Octagonal stick



404.621	4/4
404.622	3/4
404.623	1/2

- Better quality
- Round stick



404.631	4/4
---------	-----

- Selected quality
- Round stick



404.635	4/4
---------	-----

- **Liuteria Maestro**
- Whalebone wrapping (imitation)
- Ebony frog with Parisian eyelet
- Ebony slide with mother-of-pearl
- Three part silver leg with artistic dot/cross inlays and mother-of-pearl eyelet
- Silver screw
- **Stamped „Liuteria“**
- Good quality



404.641	Round
404.642	Octagonal

- Better quality



404.645	Round
404.646	Octagonal

- Orchestra bow
- Ebony frog with Parisian eyelet
- Ebony slide with mother-of-pearl
- Silver screw
- Good quality
- Octagonal stick
- Stamped "Atelier Jaeger"



404.647	4/4
---------	-----

GEWA Cello bow Franz Bergner

- Nickel silver with stamp



404.651	Round
404.652	Octagonal

GEWA Cello bow Gérard Moulin

- Nickel silver with stamp



404.675	Round
404.676	Octagonal

GEWA Cello bow Robert Reichel

- Nickel silver with stamp



404.681	Round
404.682	Octagonal

GEWA Cello bow Peter Stenzel

- Nickel silver with stamp



404.687	Round
404.688	Octagonal

GEWA Strings

GEWA Cello bow W.R. Wild

- Nickel silver with stamp



404.691	Round
404.692	Octagonal

W. E. DÖRFLER Cello bow

- Ligne Bohème
- Round premium pernambuco stick
- Sartory head
- Ebony frog
- Parisian eye
- 3-piece. leg
- Goldfish inlay
- Silver with „Egidius Dörfler“ stamp



404.717	Round
---------	-------

OTTO DÜRRSCHMIDT Cello bow

- Silver with stamp
- Very well-chosen stick
- Ebony frog with Parisian eyelet
- Eye with silver ring
- **GEWA exclusive model**



404.723	Round
404.724	Octagonal

GEWA Cello bow Robert Reichel

- Silver with stamp



404.751	Round
404.752	Octagonal

GEWA Cello bow W.R. Wild

- Silver with stamp



404.781	Round
404.782	Octagonal

GEWA Cello bow Carbon Jeki

- Nickel silver
- Ebony frog with slide
- Natural hair
- Parisian eye



404.790	4/4
404.791	3/4
404.792	1/2
404.793	1/4
404.794	1/8

NEW

GEWA Cello bow Carbon

- Round stick
- Ebony frog with Parisian eyelet
- Nickel silver taping
- Natural hair



404.798	4/4
---------	-----

- Ebony frog
- German model
- Round stick

NEW



404.811	3/4
404.812	1/2
404.813	1/4
404.814	1/8

- Octagonal stick



404.821	3/4
404.822	1/2
404.823	1/4
404.824	1/8

GEWA Strings

GEWA Cello bow Carbon

- Octagonal stick
- Ebony frog
- **Stamped „Jaeger“**



404.831	3/4
404.832	1/2
404.833	1/4
404.834	1/8
404.836	1/16

- Ebony frog
- Round stick
- Better quality



404.841	3/4
404.842	1/2

GEWA Double bass bow Massaranduba

- Whalebone wrapping (imitation)
- Ebony frog
- Natural hair
- Parisian eye
- Octagonal stick
- Ebony frog with bow slides



404.815	3/4
404.816	1/2
404.817	1/4

GEWA Double bass bow Carbon

- Round stick
- Ebony frog with Parisian eyelet
- Nickel silver taping
- Natural hair



404.828	3/4
---------	-----

GEWA Double bass bow Massaranduba Student

- Ebony frog
- Natural hair
- Selected quality
- Octagonal stick
- Stamped "Atelier Jaeger"



404.847	3/4
404.848	1/2

- German model
- Round stick
- Ebony frog



404.851	3/4
---------	-----

- Orchestral bow
- Ebony frog
- Ebony slide with mother-of-pearl
- Good quality
- Octagonal stick
- **Stamped "Atelier Jaeger"**



404.853	3/4
---------	-----

GEWA Double bass bow H.Walter Zapf

- Nickel silver with stamp



404.852	Octagonal
---------	-----------

GEWA Double bass bow Erwin Mahler

- Nickel silver with stamp



404.875	Round
404.876	Octagonal

GEWA Strings

GEWA Double bass bow Robert Reichel

- Nickel silver with stamp

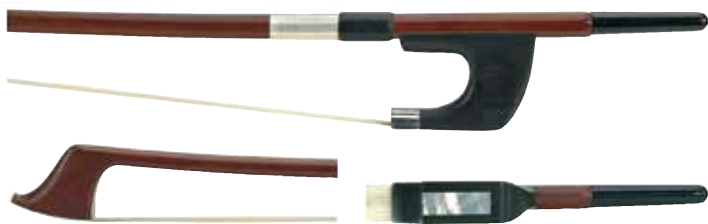

404.881

- Better quality
- Round stick
- Ebony frog with back plate



404.921 3/4

GEWA Double bass bow W.R. Wild

- Nickel silver with stamp



404.891

GEWA Double bass bow Pernambuco wood French

- Round stick
- Ebony frog



404.925 3/4

GEWA Double bass bow H.Walter Zapf

- Silver with stamp



404.895 Octagonal

GEWA Double bass bow W.R. Wild

- Nickel silver with stamp



404.941

- Round stick
- Ebony frog



404.905 3/4

404.906 1/2

404.907 1/4

GEWA Double bass bow Fiddle, Discant- and Alto Gambe

- Round stick
- Ebony frog



404.961 Brasil wood

404.962 Pernambuco wood

- Octagonal stick
- Ebony frog



404.911 3/4

404.912 1/2

404.913 1/4

GEWA Double bass bow Tenorgambe

- Round stick
- Ebony frog



404.965 Brasil wood

404.966 Pernambuco wood

- Octagonal stick
- Ebony frog
- With upper and lower slide



404.915 3/4

404.916 1/2

404.917 1/4

GEWA Psalter bow

- Brasil wood
- Thumb leather



404.981

GEWA Strings

GEWA Nyckelharpa bow

- For Nyckelharpa and Viola D'Amore
- Playing length 38 cm
- Basic ebony frog
- Baroque head
- Thumb leather
- Straight bar



404.984

GEWA Bass bow holder

- Real leather
- Hand made
- Easy attachment to the instrument



404.990 Black



404.991 Brown

GEWA Bow cover Classic

- For the protection of top quality bows
- Fastening by strap with stop bar
- Leather imitation black



404.995 Violin-/Viola bows

404.997 Double bass bows, German model

GEWA Mute Trident

- For mounting on the bridge
- Ebony grooved



409.430 Double bass 4-string

- Mute remains on the instrument
- Violin shape



409.700 Violin

- Round



409.750 Violin

- Mute remains on the instrument
- Violin shape



411.700 Cello

- Round



411.750 Cello

- soft plastic



411.850 Double bass

- Tone wolf
- Chrome plated metal



411.910 Violin Pcs.+

- Rubber



411.913 3/4 a. 1/2

411.914 1/4



411.916 Viola

- Tone wolf
- Chrome plated metal



411.960 Cello

- Tone wolf
- Metal gold plated



411.961 Cello

- Rubber



411.962 Cello

- Rubber



411.972 Double bass

GEWA Mute

- Tone wolf
- Metal with plastic casing



411.950 Cello

GEWA Strings

GEWA Cello end pin Standard

- Metal pin Ø 8 mm
- 52 cm long
- Hard wood cone

413.000



GEWA Double bass end pin Standard

- Metal pin Ø 8 mm
- 33 m length
- Hard wood cone

414.000



GEWA Cello end pin Standard

- Metal pin Ø 10 mm
- 52 cm long
- Ebony cone

413.638 cone 23,5/25,5 mm

413.639 Cone 25/27 mm



GEWA Double bass end pin Standard

- Metal pin Ø 16 mm
- Hard-chrome plated
- Ebony cone

414.638 37 cm long

414.639 45 cm long



GEWA Cello end pin Standard

- Metal pin Ø 10 mm
- 62 cm long
- Ebony cone

413.648 cone 23,5/25,5 mm

413.649 Cone 25/27 mm



GEWA Double bass end pin Kombi

- Metal pin Ø 16 mm
- 47 cm long
- Ebony cone

414.651



- Metal pin Ø 8 mm
- 52 cm long
- Ebony cone
- Chrome plated metal parts

413.850



GEWA Double bass end pin

- Ø 10 mm
- Favourable resonance characteristics
- Ultra Light
- Carbon fibre end pin
- 40 cm long
- With exchangeable chrome tip

414.706 Cone 29/32 mm

414.707 Cone 31,5/34,5 mm



- Carbon pin Ø 8 mm
- 52 cm long
- Boxwood crown
- Gold plated metal parts

413.868



GEWA C-bow protection

- It can be avoided, the shiver when the metal of the bow hits the edge of the violin:

GEWA Cello end pin

- Favourable resonance characteristics
- Ultra Light
- Carbon fibre end pin
- Ø 10 mm
- 60 cm long
- With exchangeable chrome tip

413.910 Cone 24,0/26,3 mm

413.911 Cone 25,0/27,3 mm



- Most suitable for beginners
- Protects the instrument from scratches, nicks and lacquering damages
- Saves costs for expensive and avoidable repairs
- Preserves the value of your violin
- Suitable for 4/4 violins
- Can be easily attached and removed
- Made of soft, lightweight urethane



GEWA Cello end pin Arc

- Ultra Light
- Carbon fibre endpin Ø 10 mm
- 61 cm long
- Synthetic barrel

413.915 Cone 26/28 mm



414.900

- Replacement end pin set



413.916

GEWA Cello end pin tip

- Chrome plated, angled metal tip to screw onto end pin



413.920

GEWA Strings

GEWA Floor Protector Universal



415.000 Cello

GEWA Floor Protector Xerox

- 50 mm wide black strap
- Adjustable from 40 - 80 cm



415.010 Cello

415.015 Bass

GEWA Floor Protector Anchor

- Leather strap with loops
- Underside slip-free rubber
- Chord for attachment to chair leg
- Can be rolled up



415.020

- beneficial resonance features
- Total length approx. 60 cm
- Strap for mounting on the chair legs
- Length infinitely adjustable
- Underside of end pin holder made of slip free rubber
- Small, easily transportable



415.310

- Cello shape



415.315

GEWA Floor Protector

- 5 different positions
- Both ends made of wood
- Adjustable nylon strap
- Non-skid



415.318 Walnuss



415.319 Maple

GEWA Wolf eliminator Violin/Viola Wolf tone tube



415.353 Chrome

415.354 Gold

GEWA Wolf eliminator Resonator

- Special clamp for glueing in the GÜTH resonator item no. 415.350 - 352



415.355

GEWA Wolf eliminator Cello Wolf tone tube



415.360 Chrome

Pcs.+

415.361 Gold

Pcs.+

GEWA Wolf eliminator Double bass Wolf tone tube



415.362 Chrome

415.363 Gold

GEWA Bow corrector

- For learning the correct bow movement



415.370 Violins 4/4 - 3/4

415.371 Violins 1/4 - 1/2

415.373 Cello 4/4-1/2

415.374 Cello 1/4-1/16

GEWA Violin end pins Ebony wood



- Tyrolean shape, 2 pieces
- Yellow brass
- 4-string

415.458 4/4 - 3/4

415.459 1/2 - 1/4

415.460 1/8 - 1/16

GEWA Violin end pins Model Hill Boxwood

- Black button



415.462 4/4 - 3/4

GEWA Violin end pins Model Hill Ebony wood

- Black button



415.464 4/4 - 3/4

GEWA Violin end pins Model Hill Ebony wood

- White button



415.465 4/4 - 3/4

GEWA Violin end pins Ebony

- Ebony with eyelet



415.467 4/4 - 3/4

GEWA Violin end pins Ebony

- With golden ball



415.468 4/4 - 3/4

- 2-part
- Nickel plated finish
- 4-string



415.473 4/4 - 3/4

- Engraved brass
- 4-string



415.474 4/4 - 3/4

- Nickel plated finish
- 5-string



415.476 4/4 - 3/4

- Tyrolean shape, 2 pieces
- Yellow brass
- 4-string



415.477 4/4 and 3/4 Size.

415.477.501 4/4 and 3/4 size Antique

- Nickel plated finish
- 4-string



415.481 4/4 - 3/4

- 5-string



415.482 4/4 - 3/4

GEWA Strings

RUBNER Single bass machine head

- Brass
- 4-string



415.487	4/4 - 3/4
415.487.501	4/4 - 3/4 Antique

RUBNER Single bass machine head

- Nickel-plated
- 4-string



415.488	4/4 - 3/4
---------	-----------

GEWA Double bass machine head turner



415.490	All sizes black
415.491	All sizes red

GEWA Violin peg Ebony

- Standard
- Packing unit 4 pcs



415.530	4/4 medium
415.531	4/4 strong
415.532	3/4 medium
415.533	3/4 strong
415.534	1/2 medium
415.535	1/2 strong
415.536	1/4 medium

GEWA Violin peg Ebony

- Honed
- Packing unit = 4 pcs



415.550	4/4 medium
415.554	4/4 strong
415.557	3/4 medium
415.558	3/4 strong
415.559	1/2 medium
415.560	1/2 strong

GEWA Violin peg Ebony

- Top quality
- Packing unit 4 pcs



415.750	Medium
415.760	Strong

GEWA Violin peg Hill model Ebony

- White button
- Packing unit = 4 pcs



415.770	Medium
415.780	Strong

GEWA Violin peg Hill model Boxwood

- Black button
- Packing unit = 4 pcs



416.100	Medium
416.101	Strong

GEWA Violin peg Hill model. Heart shape. Ebony rings Boxwood

- Packing unit = 4 pcs



416.102	Medium
416.103	Strong

GEWA Violin peg Ebony

- Basic
- Packing unit 4 pieces



415.500	4/4 medium
415.501	4/4 strong
415.502	3/4 medium
415.503	3/4 strong
415.504	1/2 medium
415.505	1/2 strong
415.506	1/4 medium
415.507	1/4 strong
415.508	1/8 medium
415.509	1/8 strong
415.510	1/16 medium
415.511	1/16 strong

GEWA Strings

GEWA Violin outfit Ebony

- finest selected woods
- 4 GEWA pegs
- Tailpiece English model with boxtree rings
- Chin rest with high-quality screws
- End button



416.260 Guarneri model chin rest

GEWA Viola outfit Ebony

- NEW** • finest selected woods
- 4 GEWA pegs
- Tailpiece, English model with boxwood rings
- Chin rest with high-quality screws
- End button



416.271 4/4

GEWA Violin outfit Boxwood

- finest selected woods
- 4 GEWA pegs
- Tailpiece English model with rings
- Chin rest with high-quality screws
- End button



416.262 Guarneri model chin rest

GEWA Viola outfit Boxwood

- NEW** • Finely selected woods
- 4 GEWA pegs
- Tailpiece, English model with ebony rings
- Chin rest with high-quality screws
- End button



416.273 4/4

GEWA Strings

GEWA Cello outfit Ebony

- Finely selected woods
- 2 GEWA pegs with rings
- Tailpiece, English model with 4 integrated fine tuners
- Ebony cone
- Metal pipe rod
- End button



416.281 4/4

GEWA Cello outfit Boxwood

- Finely selected woods
- 4 GEWA pegs
- Tailpiece, English model with 4 integrated fine tuners
- Boxwood crown
- Metal pipe rod
- End button



416.283 4/4

GEWA Viola peg Ebony

- Basic
- Packing unit 4 pieces



416.480 Medium
416.481 Strong

GEWA Viola peg Ebony

- Standard
- Packing unit 4 pcs



416.500 Medium
416.510 Strong

GEWA Viola peg Ebony

- NEW**
- Honed
- Packing unit = 4 pcs



416.550 Medium
416.560 Strong

GEWA Viola peg Hill model Boxwood

- Black button
- Packing unit = 4 pcs



417.100 Medium
417.101 Strong

GEWA Viola peg Hill model Boxwood

- Heart shape
- Black button and ring
- Packing unit = 4 pcs



417.105 Medium
417.106 Strong

GEWA Cello peg Ebony

- NEW**
- Basic
- Packing unit 4 pieces



417.500 4/4 medium
417.501 4/4 strong
417.502 3/4 medium
417.503 3/4 strong
417.504 1/2 medium
417.505 1/2 strong
417.506 1/4 medium
417.507 1/4 strong
417.508 1/8 medium
417.509 1/8 strong

GEWA Cello peg Ebony

- Standard
- Packing unit 4 pcs



417.520 4/4 medium
417.521 4/4 strong
417.522 3/4 medium
417.523 3/4 strong
417.524 1/2 medium

GEWA Cello peg Ebony

- Honed
- Packing unit = 4 pcs



417.541 4/4 medium
417.542 4/4 strong
417.543 3/4 medium
417.544 3/4 strong

GEWA Cello peg Hill model Boxwood

- Black button
- Packing unit = 4 pcs



418.090 4/4 medium
418.091 4/4 strong

GEWA Strings

GEWA Violin tailpiece Ebony



418.301	4/4
418.302	3/4
418.303	1/2

GEWA Violin tailpiece Hill model Boxwood

- Black rings



418.583	4/4 length 114 mm
418.585	4/4 length 108 mm

GEWA Viola tailpiece Ebony



419.250	125 mm
---------	--------

GEWA Cello tailpiece Hill model Boxwood

- Black rings



420.383	4/4
---------	-----

GEWA Cello tailpiece Hill model

- 4 browned fine tuners



420.904	Ebony
420.906	Boxwood

GEWA Chin rest Dresden

- Violin
- Synthetic



431.100	4/4-3/4
431.110	1/2-1/4
431.113	1/8-1/16

GEWA Chin rest Dresden

- Violin
- Ebony



431.150	4/4-3/4
431.152	1/2-1/4
431.154	1/8-1/16

GEWA Chin rest Mulco

- Violin
- Synthetic



431.200	4/4 - 3/4
---------	-----------

GEWA Chin rest Teka

- Violin



431.300	Synthetic
431.301	Synthetic 1/2 -1/4
431.302	Synthetic mat
431.303	Synthetic mat 1/2-1/4
431.320	Boxwood
431.350	Ebony
431.350.501	Lefthand model Ebony 4/4-3/4
431.351	Ebony 1/2 - 1/4
431.351.501	Lefthand model Ebony 1/2-1/4
431.356	Viola synthetic
431.358	Viola synthetic, matt

GEWA Chin rest Wendling

- Violin + Viola



431.400	Violin Synthetic 4/4-3/4
431.401	Violin Synthetic 1/2-1/4
431.403	Violin Synthetic 1/8
431.406	Viola synthetic
431.407	Ebony

GEWA Chin rest Guarneri

- Hard wood, black



431.500	4/4-3/4
431.501	1/2
431.502	1/4
431.503	1/8
431.504	Viola

GEWA Strings

GEWA Chin rest Flat

- Violin
- Extremely low



431.760	Boxwood
431.780	Ebony
431.781	Ebony 1/2
431.782	Ebony 1/4

GEWA Chin rest Hill

- Violin



431.820	Boxwood
431.850	Ebony

GEWA Chin rest Hubermann

- Violin



431.920	Boxwood
431.950	Ebony

GEWA Chin rest Berber

- Violin



432.120	Boxwood
432.150	Ebony
432.151	Ebony 1/2 - 1/4

GEWA Chin rest Kantuscher

- Violin



432.220	Boxwood
432.250	Ebony

GEWA Chin rest Stüber

- Violin



432.320	Boxwood
432.350	Ebony

GEWA Chin rest Schmidt

- Violin



432.420	Boxwood
432.450	Ebony
432.451	Ebony 1/2 - 1/4

GEWA Chin rest Fleisch

- Violin



432.520	Boxwood
432.550	Ebony

GEWA Chin rest Paganini

- Violin



432.560	Boxwood
432.570	Ebony

GEWA Chin rest Vermeer

- Violin



432.620	Boxwood
432.650	Ebony

GEWA Chin rest Morawetz

- Violin



432.720	Boxwood
432.750	Ebony
432.751	Ebony 1/2 - 1/4

GEWA Chin rest Varga

- Violin



432.762	Boxwood
432.764	Ebony

GEWA Chin rest Strobel

- Violin



432.767	Boxwood
432.769	Ebony

GEWA Chin rest Spohr

- Violin



432.777	Boxwood
432.779	Ebony

GEWA Chin rest PVS

- Violin



432.820	Boxwood
432.850	Ebony

GEWA Strings

GEWA Chin rest Guarneri

- Violin



432.863	Boxwood
432.865	Ebony
432.865.501	Lefthand model Ebony 4/4-3/4
432.866	Ebony 1/2 - 1/4
432.866.501	Lefthand model Ebony 1/2-1/4

GEWA Chin rest Flesch round

- Violin



432.874	Boxwood
432.878	Ebony
432.878.501	Lefthand model Ebony 4/4-3/4
432.879	Ebony 1/2 - 1/4
432.879.501	Lefthand model Ebony 1/2-1/4

GEWA Chin rest Neukölln

- Violin



432.883	Boxwood
432.885	Ebony

GEWA Chin rest Model Genf

- With Hill screws
- Violin



432.901	Boxwood
432.904	Ebony

GEWA Chin rest Model Guarneri

- With Hill screws
- Violin



432.930	Boxwood
432.932	Ebony

GEWA Chin rest Model Guarneri

- With gold plated Hill screws
- Violin



432.934	Boxwood
432.936	Ebony

VAAGUN Chinrest Cover

- Easy to mantle and dismantle
- No chin contact with chin rest / chin rest screws
- Good for allergic persons
- Reduces skin irritation
- Prevents slipping
- Supports a relaxed position
- Additional padding
- Lessens fatigue when practising extensively
- Comfortable for bearded persons
- Size S fits most 1/4-1/8 violins
- Size M fits most 3/4-1/2 violins
- Size L fits most 4/4 violins and viola
- Size XL fits most extra large chin rests
- Microfibre
- Brown



432.950	Size L
432.951	Size M
432.952	Size S
432.953	Size XL

- Microfibre
- Brown
- Round

432.954	Size L
---------	--------

- Cotton
- Black

432.956	Size L
432.957	Size M
432.958	Size S
432.959	Size XL

- Cotton
- Black
- Round

432.960	Size L
---------	--------

GEWA Chin rest screw

- Titan, shiny polished surface



434.864	Violin 27 mm
434.865	Viola 32 mm
434.866	Viola 36 mm
434.867	Viola 40 mm

- Titan, matt black with silky sheen



434.869	Violin 27 mm
434.870	Viola 32 mm
434.871	Viola 36 mm
434.872	Viola 40 mm

GEWA Strings

GEWA Chin rest screw

- Violin
- Sturdy model



434.880

- Violin
- Hill model
- Pair



434.881 Nickel plated finish

434.882 Gold-plated finish

- Violin
- Original Wolf
- Easily assembled
- Violin 4/4 - 1/4 and Viola
- Pair



434.886 Standard

434.887 Gold

- Viola



434.890 29 mm

434.891 35 mm

434.892 40 mm

434.893 50 mm

- Viola
- Hill model
- Pair



434.894

GEWA Chin rest key



434.899 Chrome

434.900 Gold

GEWA Replacement cork



434.930 For Chin rest



434.935 For screw

GEWA Violin/viola bow hair Mustang

- Unbleached natural hair
- Length - 80 cm



450.920 Single layer, normal strength

450.921 12 pcs 450.920

450.922 Single layer, extra strong

450.923 12 pcs 450.922

GEWA Cello bow hair Mustang

- Unbleached natural hair
- Length - 74 cm



450.924 Single layer, normal strength

450.925 12 pcs 450.924

GEWA Double bass bow hair Mustang

- Unbleached natural hair
- Length - 74 cm

450.926 Single layer white

450.927 Single layer black

GEWA Bow hair Mustang bulk

- Unbleached natural hair
- White
- Approx. 1 kg weight (± 250 g) Price/Gramm



450.930 Length - 800 mm

450.932 Length - 750 mm

450.934 Length - 700 mm

GEWA Rosin Liuteria

- Securely lockable synthetic box



450.999 Violin/Viola



451.000 Cello

GEWA Double bass rosin

- Securely lockable synthetic box



451.180 Bass

GEWAPURE Rosin

- Securely lockable synthetic box



PS408.200 Violin/ Viola

PS408.205 Cello

PS408.210 Double bass

GEWA Strings

GEWA Violin/viola stand Light

- Synthetic
- Instrument rests with soft rubber
- Depth of side arms **adjustable** 60 - 83 mm
- Low weight of only **180 gr**
- Dimensions when packed: 213 x 92 x 90 mm
- Can also be used for ukulele



- Suitable for all Cello sizes
- Width 30 cm
- Depth 12 -14 cm
- Cork covered instrument rest



452.210

GEWA Violin table stand BSX

- Felt covered instrument rest
- Depth of the instrument rest surface 60/45 mm
- Black



452.234



452.215

GEWA Violin/ viola table stand

- Wood
- Felt-covered instrument rest
- Instrument rest extractable to 16 cm



452.236

GEWA Double bass stand GEWA STANDS

- Gear-System
- Foldable
- Height adjustable
- Black steel tube
- Height 60-115 cm
- Weight 3,2 kg



452.216

GEWA Violin/ viola table stand

- Cork covered instrument rest
- Instrument rest extractable to 16 cm
- Black
- Weight 0,3 kg



452.219

GEWA Violin/viola stand BSX

- Violin stand
- Foldable
- Height 38 - 54 cm
- Weight 0,6 kg



452.240

GEWA Double bass stand GEWA STANDS McNutt Bass Cradle

- Novel bass stand
- Developed and **patented** by **Dennis McNutt**
- **Stable stand and easy handling**
- Made of black aluminium
- Soft padding on rests
- Standing surface 87 x 60 x 75 cm
- Height 86 cm
- **Compact dimensions** (43 x 7,5 x 10 cm)
- **Lightweight** (1,010 kg)
- incl. bag

452.221

GEWA Cello stand GEWA STANDS

- Gear-System
- Foldable
- Height adjustable
- Black steel tube
- Height 60-90 cm
- Weight 3,0 kg



452.250



452.232

GEWA Strings

GEWA Saddle Ebony

- Completely fitted
- Package 5 pcs. price indication per piece



415.446	Violins top
415.448	Viola top
415.452	Cello top
415.454	Double bass top



415.447	Violins bottom
415.449	Viola bottom
415.453	Cello bottom
415.455	Double bass bottom

GEWA Violin sound post

- 1 Rod = 6 soundposts

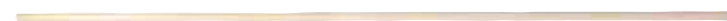

457.123	1/8, Ø 4,8 mm
457.124	1/4, Ø 5,2 mm
457.128	3/4, Ø 5,8 mm
457.130	4/4, Ø 6,2 mm

GEWA Viola sound post

- 1 Rod = 6 soundposts



457.133	Ø 6,5 mm
457.135	Ø 7,0 mm

GEWA Cello sound post

- 1 Rod = 2 soundposts



457.136	1/2, Ø 9,5 mm
457.137	1/8, Ø 8,5 mm
457.138	3/4, Ø 10,5 mm
457.139	1/4, Ø 9,0 mm
457.140	4/4, Ø 11,0 mm
457.142	4/4, Ø 12,0 mm

GEWA Double bass sound post

- 1 Rod = 1 soundpost



457.143	1/2-3/4, Ø 16,0 mm
457.144	1/4-1/8, Ø 13,0 mm
457.145	4/4, Ø 19,0 mm

GEWA Purfling

- Fiber-maple-fiber
- Completely glued and cut
- 75 cm long
- Package 10 pcs. price indication for 1 piece



457.200	Violin 0,3/0,7/0,3 mm
457.205	Viola 0,3/0,8/0,3 mm
457.210	Cello 0,5/0,8/0,5 mm
457.215	Double bass 0,5/1,2/0,5 mm

GEWA Lacquer set

- For touching up spirit and oil varnish
- Can be mixed
- 100ml each in shades transparent, golden yellow, brown, black, red, yellow



463.400

GEWA Matt varnish

- Spirit soluble
- Fast drying
- 50 ml bottle



463.450

GEWA Violin cover varnish

- 250 ml
- Spirit-based
- Delivered in tin can



463.500 Transparent

GEWA Violin base varnish

- 250 ml
- Spirit-based
- Delivered in tin can



463.550

GEWA Violin colour varnish

- 250 ml
- Spirit-based
- Delivered in tin can



463.602	Red
463.604	Yellow
463.607	Brown
463.608	Gold-yellow

GEWA Strings

GEWA Guitar varnish

- 250 ml
- Spirit-based
- Delivered in tin can



463.650 Premium light

GEWA Shellac polish

- 250 ml
- Spirit-based
- Delivered in tin can



463.700 Transparent

GEWA High gloss polish

- 250 ml
- Spirit-based
- Delivered in tin can



463.750 Red

GEWA Stick varnish

- 250 ml
- Spirit-based
- Delivered in tin can



463.800 Red

GEWA Violin colour varnish

- 250 ml
- Oil base
- Delivered in tin can



463.850 Transparent

463.852 Red

463.854 Yellow

463.857 Brown

463.858 Gold-yellow

GEWA Primer

- Potash soluble glass



464.000 250 ml

GEWA Wood stain

- Fine quality
- 250 ml tin can



464.001 Alt 421

464.002 Red

464.004 Yellow

464.007 Brown

464.008 Orange

464.050 Ebony

GEWA Colour extract

- For spirit and oil varnish
- 100 ml Glas bottle
- 9-digit numbers only available in 1000 ml



464.102 Red

464.104 Yellow

464.107 Brown

464.108 Gold-yellow

464.110 Black

GEWA Thinner for oil varnish

- 250 ml



464.200

GEWA Spirit

- 99,9 %
- 500 ml



464.280

GEWA Varnish filler

- Spirit soluble
- Fast drying
- 50 ml bottle



464.290

GEWA Polishing oil

- 1A
- 1 Liter



464.295

GEWA Pearl glue

- Acid free
- 1 kg



464.300

GEWA Shellac

- Lemon
- 250 g



464.370

GEWA Venetian turpentine

- 100 ml bottle



464.380

GEWA Linseed oil

- 250 ml bottle



464.382

GEWA Pumice

- Powder
- Fine 250 g



464.384

GEWA Strings

GEWA Brush Special edition

- 2,5 cm width



464.400

- 4,0 cm width



464.450

- 5,0 cm width



464.500

- 6,5 cm wide



464.550

- 10 cm width



464.555

GEWA Brush Bear hair

- Extra strong



464.570 5 cm wide

464.575 8 cm wide

GEWA Retouching brush Red marten hair



464.600 Pointed No. 2

464.650 Pointed No. 4

464.700 Pointed No. 6

GEWA Retouching brush Polecat hair



464.710 Flat No. 8

464.720 Flat No. 12

464.730 Flat No. 20

- 23 x 28 cm
- SIA

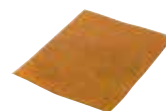

464.732 Grit 120

464.733 Grit 150

464.734 Grit 180

464.735 Grit 220

464.736 Grit 280

- Water proof

464.738 Grit 600

GEWA Abrasive paper Micro Mesh

- Grinding and polishing mesh
- With oil or water
- For finish grinding

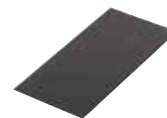

464.742 Grit 1500

464.743 Grit 2400

464.744 Grit 3600

464.745 Grit 6000

464.746 Grit 8000

464.747 Grit 12000

GEWA Glue brush

- Metal free



464.750 Ø 10 mm

464.760 Ø 14 mm

LUTHIER Cleanser

- Cleaning liquid for string instruments
- 50 ml bottle



464.850

GEWA Peg reamer Violin

- 3-cutting edges
- Cutting length 135 mm
- Taper 1:30
- Ø 5,5 - 10,0 mm



465.900

465.905 Tin coated

- Spiral-cutting length 135 mm
- Taper 1:30
- Ø 5,5 - 10,0 mm



465.910

465.915 Tin coated

- Cutting length 130 mm
- Taper 1:20
- Ø 3,5 - 10,0 mm



465.920

465.925 Tin coated

- Spiral-cutting length 130 mm
- Taper 1:20
- Ø 3,5 - 10,0 mm



465.930

465.935 Tin coated

GEWA Strings

GEWA Peg reamer Violin

- Cutting length 105 mm
- Taper 1:30
- Ø 4,0 - 7,5 mm



465.940

465.942 Tin coated

- Spiral-cutting length 105 mm
- Taper 1:30
- Ø 4,0 - 7,5 mm



465.944

465.946 Tin coated

- 3-cutting edges
- Taper 1:25
- Ø 8 - 16,0 mm
- Cutting length 200 mm



466.040

466.042 Tin coated

- Spiral-cutting length 200 mm
- Taper 1:25



466.044

466.046 Tin coated

GEWA End pin reamer Cello

- 3-cutting edges
- Cutting length 212,5 mm
- Taper 1:17
- Ø 15,0-27,5 mm



466.061

466.062 Spiral reamer

GEWA End pin reamer Double bass

- 3-cutting edges
- Cutting length 221 mm
- Taper 1:17
- Ø 23,0-36,0 mm



466.066

466.067 Spiral reamer

GEWA Peg shaper Violin

- 4-part
- Cutting length 50 mm
- Taper 1: 30
- 6x4,3/6,5x4,8/7x5,3/7,5x5,8 mm



466.073

GEWA Peg shaper Violin/Viola

- 4-part
- Cutting length 50 mm
- Taper 1: 30
- 8x6,3/8,5x6,8/9x7,3/9,5x7,8 mm



466.085

466.086 Replacement blade

GEWA Peg shaper Violin/Viola

- 4-part
- Cutting length 50 mm
- Taper 1: 20
- 7,2x4,7/8x5,55/8,7x6,2/9,5x7,0 mm



466.095

GEWA Peg shaper Cello

- 2-part
- Cutting length 80 mm
- Taper 1: 25
- Light, 10,7 x 7,5 / 11,5 x 8,3 mm

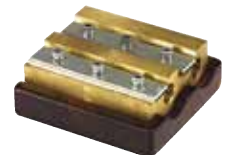

466.200

466.201 Replacement blade

- Medium, 12,2 x 9 / 13 x 9,8 mm

466.205

- Heavy, 13,7 x 10,5 / 14,5 x 11,3 mm

466.210

GEWA Strings

GEWA Glue clamp Violin

- Single
- Winding in handle (32 pieces for 1 corpus)



466.420

- Single
- Winding in handle (42 pieces for 1 corpus)



466.520

- 6-part

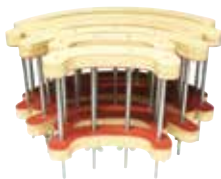

466.540 4/4

GEWA Glue clamp Double bass

- Winding in handle
- Single



466.620

GEWA Repair screw Violin

- Glue repellent synthetic
- Brass winding
- Easy to turn screw
- High precision
- Inner bout



466.670

- Corners



466.671

- Outer bout



466.672

GEWA Top clamps

- Model Voigt
- Forged round steel frame
- Knurled Screws
- Movable pressure cap
- Opening/Depth



466.710 30/90 mm

466.720 35/125 mm

466.730 35/175 mm

466.740 40/225 mm

466.745 40/285 mm

GEWA Repair clamp

- Aluminum clamp
- Movable pressure cap
- Very light
- Opening/Depth



466.760 30/90 mm

466.761 40/105 mm

466.762 40 x 125 mm

466.763 45/150 mm

466.764 50/220 mm

466.765 40/240 mm (185)

466.766 Set with 6 pieces

GEWA Edge clamp

- 15 x 12 mm
- 2 screws
- Yellow brass
- Movable pressure cap



466.810

GEWA Edge clamp

- 15 x 15 mm
- Yellow brass
- Movable pressure cap



466.812

GEWA Crack clamp

- Yellow brass



466.815 10 x 25 mm

466.816 15 x 40 mm

GEWA Edge clamp

- Yellow brass
- Opening/Depth



466.820 15/15 mm

- Forged steel shackle
- Movable pressure cap
- Strong thread
- Opening/Depth



466.828 22/12 mm



466.830 27/15 mm



466.832 40/35 mm



466.834 90/35 mm

466.836 135/45 mm



466.838 150/80 mm

GEWA F-hole clamp set

- 4-part
- Metal
- Movable pressure cap with leather layer
- Opening/Depth
- 25/30, 25/50, 25/80, 25/100 mm

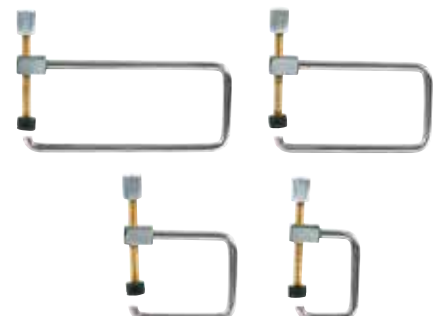

466.844

GEWA Strings

GEWA F-hole clamp Set

- Metal
- Wooden jaws
- Strong spring
- 44 pieces are sufficient for 1 wooden tun ring, body size 42 cm



466.855

GEWA Parallel hand screws

- Steel browned
- Double screws
- Opening/Depth



467.116 40/70 mm

GEWA Wooden clamp

- Opening/depth



467.150 200/110 mm

467.160 200/140 mm

467.170 200/200 mm

467.172 250/200 mm

GEWA Side clamp

- For glueing of loose sides to lower block when instrument is closed
- Violin



467.180 Violin

467.185 Cello

GEWA Crack clamp

- Flat profil brass shafts
- Drehbare, leimabstoßende Holz-Backen

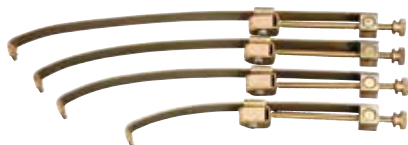

467.505 Violin, 4 parts

GEWA Crack clamp GEWA crack clamp

- Brass
- Width adjustable
- Rotable jaws
- Two distance screws: vertically and horizontally adjustable



467.630 180 mm

GEWA Crack clamp

- Brass
- Double sided
- For violin and viola
- Span width 280 mm
- 2 rotatable jaws
- 2 distance screws each, vertically and horizontally adjustable



467.640

GEWA Edge clamp

- Spring guide
- Horizontally adjustable
- 2 screws
- Opening: 11,5 mm
- Depth: 19,5 mm
- Span width: 7 mm



467.647

- Swiss model
- Vertically and horizontally adjustable
- 4 screws
- Opening: 16,5 mm
- Depth: 25 mm
- Span width: 7 mm



467.648

GEWA Purfling cutters

- Brass body
- Mittenwald model
- 2 steel knives for purfling lead channel



481.914

GEWA Purfling channel cleaner

- Metal
- With wooden handle
- For cutting of the purfling channel



481.920

GEWA Hammer

- For edge inserts



481.925

GEWA File

- Micro Mesh flex



482.110 Grain 3600/6000/12000

482.122 Grain 180/240

482.124 Grain 320/360

482.126 Grain 400/600

GEWA needle file

- Round with handle
- Cut 3



482.905

- Triangular with handle
- Cut 3



482.910

- Half round with handle
- Cut 3



482.920

- Set with 6 pieces

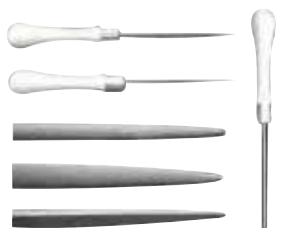

482.935

GEWA End button remover Yellow brass

- Yellow brass
- 7 x 7 mm
- With slip-proof sheath
- To gently remove end buttons as well as to ensure secure hold while working



485.006

GEWA Strings

GEWAPURE Cello Gig-Bag Classic CS 01

- 3 mm foam padding
- Large music sheet pocket
- String pocket
- 2 bow pockets
- Web carrying handle
- 2 padded, adjustable rucksack straps
- TEX black



PS235.000*	4/4 Size
PS235.001*	3/4 Size
PS235.002*	1/2 Size
PS235.003*	1/4 Size
PS235.004*	1/8 Size

GEWAPURE Double bass gig-bag Classic BS 01

- 3 mm foam padding
- Large music sheet pocket
- String pocket
- Accessory pocket
- Bow pocket
- 2 belt handles
- TEX black



PS240.000*	4/4 Size
PS240.001*	3/4 Size
PS240.002*	1/2 Size
PS240.003*	1/4 Size
PS240.004*	1/8 Size

GEWAPURE Cello Gig-Bag Classic CS 25

- 25 mm tricot interior padding
- Two rollers for easy transport
- Exterior tearproof and water protected
- Bow pocket also for bow case useable
- Music sheet- and string pocket, extra accessory pocket
- Securely attached, padded rucksack assembly
- 7 Comfortable handles, reflector strips
- Weight approx. 3,6 kg.
- Available in black



PS236.000	4/4 Size
PS236.001	3/4 Size

GEWAPURE Double bass gig-bag Classic BS 25

- 25 mm tricot interior padding
- **Two rollers for easy transport**
- Exterior tearproof and water protected
- Bow pocket also suitable for bow case
- Rucksack assembly padded and adjustable
- Large music sheet- and string pocket, extra accessory pocket
- 8 Comfortable handles, reflector strips
- Weight approx. 6,3 kg
- Available in black



PS241.000*	4/4 Size
PS241.001*	3/4 Size

GEWA Strings

GEWA Cello Gig-Bag Premium

- Added side protection on head and endpin
- **10 mm foam padding**
- 2 detachable rucksack straps, shoulder strap
- Underlayed zipper
- Music sheet and string pocket
- Bow pocket for 2 bows
- **Super light weight: Approx. 1.8 kg.**
- **Added side protection on endpin, bridge and head**
- 10 mm Tricot interior padding
- Bow pocket suitable for bow case
- Attached rucksack straps
- Large sheet music and string pocket, extra accessory pocket
- Reflective strips on front and back
- **Safety strap on endpin**
- Material GEWA-Tex black



291.400	4/4
291.410	3/4
291.420	1/2
291.430	1/4
291.440	1/8
291.450	7/8

GEWA Cello Gig-Bag PRESTIGE

NEW

- 25 mm tricot interior padding
- **YKK Zips**
- Added side protection on endpin, bridge and head
- **Bow pocket reinforced with wooden shell**
- Large sheet music and string pocket, extra accessory pocket
- Attached rucksack straps
- Reflective strips on front and back
- **Safety strap on endpin**
- Material GEWA-Tex black

NEW



291.500	4/4
291.510	3/4

- **With two wheels for easy transport**
- 25 mm tricot interior padding
- **YKK Zips**
- Added side protection on endpin, bridge and head
- **Bow pocket reinforced with wooden shell**
- Large sheet music and string pocket, extra accessory pocket
- Attached rucksack straps
- Reflective strips on front and back
- **Safety strap on endpin**
- Material GEWA-Tex black

NEW



291.600	4/4 Rolly
291.610	3/4 Rolly

GEWA Strings

GEWA Double bass gig-bag Premium

- **Added side protection on endpin, bridge and head**
- 10 mm Tricot interior padding
- Bow pocket suitable for bow case
- Attached rucksack straps
- Large sheet music and string pocket, extra accessory pocket
- Reflective strips on front and back
- **Safety strap on endpin**
- Material GEWA-Tex black



293.400	4/4
293.410	3/4
293.420	1/2
293.430	1/4
293.440	1/8

GEWA Double bass gig-bag PRESTIGE

NEW

- 25 mm tricot interior padding
- **YKK Zips**
- Added side protection on endpin, bridge and head
- **Bow pocket reinforced with wooden shell**
- Large sheet music and strings pocket, extra accessory pocket
- Attached rucksack straps
- Reflective strips on back and front
- **Safety strap on endpin**
- Material GEWA-Tex black

NEW



293.500	4/4
293.510	3/4

- **With two wheels for easy transport**
- 25 mm tricot interior padding
- **YKK Zips**
- Added side protection on endpin, bridge and head
- **Bow pocket reinforced with wooden shell**
- Large sheet music and string pocket, extra accessory pocket
- Reflective strips on back and front
- **Safety strap on endpin**
- Material GEWA-Tex black

NEW



293.600	4/4 Rolly
293.610	3/4 Rolly

GEWA Strings

PURE GEWA Form shaped violin cases CVF 01

- **Structured ABS-shell**
- Sturdy locks
- Accessory compartment
- Carrying strap
- 1,75 kg
- Exterior ABS black
- Interior blue velvet



PS350.010*	4/4 Size
PS350.011*	3/4 Size
PS350.012*	1/2 Size
PS350.013*	1/4 Size
PS350.014*	1/8 Size

PURE GEWA Form shaped violin cases CVF 03

- Styrofoam shell
- Screw-attached cover with small music sheet pocket
- Padded back and sides, suspension system
- 2 sewn-on rucksack straps
- **Weight 1,2 kg**
- Exterior TEX dark blue
- Interior dark blue velvet



PS350.070*	4/4 Size
PS350.072*	3/4 Size
PS350.074*	1/2 Size
PS350.076*	1/4 Size
PS350.078*	1/8 Size
PS350.079*	1/16 Size

PURE GEWA Form shaped violin cases CVF 02

- Styrofoam shell
- Screw-attached cover with small music sheet pocket
- Padded back and sides, suspension system
- 2 sewn-on rucksack straps
- Weight 1,2 kg
- Exterior Tex black
- Interior light grey velvet



PS350.050*	4/4 Size
PS350.052*	3/4 Size
PS350.054*	1/2 Size
PS350.056*	1/4 Size
PS350.058*	1/8 Size

GEWA Strings

PURE GEWA Form shaped violin cases Polycarbonate 1.8

- **Outer shell made of polycarbonate**
- Weight approx. 1.8 kg
- Padded suspension system
- Flexible GEWA bow bridge
- GEWA swivel type holder
- Detachable accessory pouch
- Stable main handle and side handle
- 2 detachable rucksack straps
- Silk blanket
- Black interior



PS350.085	4/4 black
PS350.086	4/4 grey
PS350.087	4/4 red
PS350.088	4/4 white

PURE GEWA Violin case CVK 01

- Styrofoam shell
- Screw attached cover with music sheet pocket
- Padded back and sides, suspension system
- 2 detachable rucksack straps
- 1 shoulder carrying strap
- **Weight 2,0 kg**
- Exterior Tex black
- Interior light grey velvet



PS350.100*	4/4 Size
PS350.102*	3/4 Size
PS350.104*	1/2 Size
PS350.106*	1/4 Size

PURE GEWA Violin case CVK 02

- Styrofoam shell
- Screw attached cover with music sheet pocket
- Padded back and sides, suspension carrying system
- 2 detachable rucksack straps, 1 shoulder strap
- **Weight 2,0 kg**
- Exterior TEX dark blue
- Interior dark blue velvet



PS350.110*	4/4 Size
PS350.112*	3/4 Size
PS350.114*	1/2 Size
PS350.116*	1/4 Size

GEWA Strings

PURE GEWA Violin case CVK 03

- Wooden shell
- Screw attached cover with music sheet pocket
- Lock
- 4 swivel type bow holders with bow silk strands
- 2 accessory pockets
- String tube and blanket
- 2 detachable rucksack straps with metal snap hooks
- Solid mounted feet
- Exterior Tex black
- Interior two tone dark and moss-green velvet



PS350.120* 4/4 Size

PURE GEWA Violin case CVK 04

- **Wooden shell**
- Screw attached cover with music sheet pocket
- Lock
- 4 swivel type bow holders with bow silk straps
- Accessory compartment, blanket
- 2 detachable rucksack straps
- Weight approx. 2,3 kg
- Exterior Tex grey/bordeaux
- Interior microfibre grey



PS350.131* Composite Core = Hybrid core

- Interior dark blue velvet



PS350.125* 4/4 Size
PS350.126* 3/4 Size
PS350.127* 1/2 Size

PURE GEWA Violin case Polycarbonate 2.4

- **Outer shell made of polycarbonate**
- Weight ca.2.4 kg
- Padded suspension system
- Flexible GEWA bow bridge
- GEWA swivel type holder
- Detachable accessory pouch
- Removable padded music pocket
- Stable main handle and side handle
- 2 detachable rucksack straps
- Silk blanket
- Black interior



PS350.185 4/4 black
PS350.186 4/4 grey
PS350.187 4/4 red
PS350.188 4/4 white

GEWA Strings

PURE GEWA Viola form shaped case CVA 02

- Body length: from 33 cm up to 42 cm
- Styrofoam shell
- Screw-attached cover with small music sheet pocket
- Padded back and sides
- Suspension system
- 2 sewn-on rucksack straps
- Weight 1,5 kg
- Exterior Tex black
- Interior light grey velvet



PS352.060*	33,0 cm
PS352.061*	35,5 cm
PS352.062*	38,2 cm
PS352.063*	39,5 cm
PS352.064*	40,8 cm
PS352.065*	42,0 cm

PURE GEWA Viola case CVA 04

- Body length: from 33 cm up to 42 cm
- Styrofoam shell
- Screw attached cover with music sheet pocket
- Padded back and sides, suspension system
- 1 shoulder carrying strap
- 2 detachable rucksack straps
- **Weight approx. 2,3 kg**
- Exterior TEX dark blue
- Interior dark blue velvet



PS352.090*	33,0 cm
PS352.091*	35,5 cm
PS352.092*	38,2 cm
PS352.093*	39,5 cm
PS352.094*	40,8 cm
PS352.095*	42,0 cm

PURE GEWA Viola form shaped case CVA 03

- Body length: from 33 cm up to 42 cm
- Styrofoam shell
- Screw-attached cover with small music sheet pocket
- Padded back and sides, suspension system
- 2 sewn-on rucksack straps
- **Weight approx. 2,3 kg**
- Exterior TEX dark blue
- Interior dark blue velvet



PS352.080*	33,0 cm
PS352.081*	35,5 cm
PS352.082*	38,2 cm
PS352.083*	39,5 cm
PS352.084*	40,8 cm
PS352.085*	42,0 cm

GEWA Strings

PURE GEWA Cello case CS 02

- SPS® system for sides, bow and bridge
- Tear- and waterproof
- 10 mm High Density foam padding
- Soft handle
- Padded, anti-skid rucksack straps
- Weight approx. 3,5 kg
- Exterior - high quality Coatex



PS353.110	4/4 Size
PS353.111	3/4 Size
PS353.112	1/2 Size

PURE GEWA Bass case CB 01

- Styrofoam shell
- **Robust Conatex in black**
- Suspension system
- Additional protection on head, end pin and bridge
- Accessory compartment
- With wheels and handles
- Interior velvet black



PS353.130	3/4 Size
-----------	----------

300.111 - 300.121

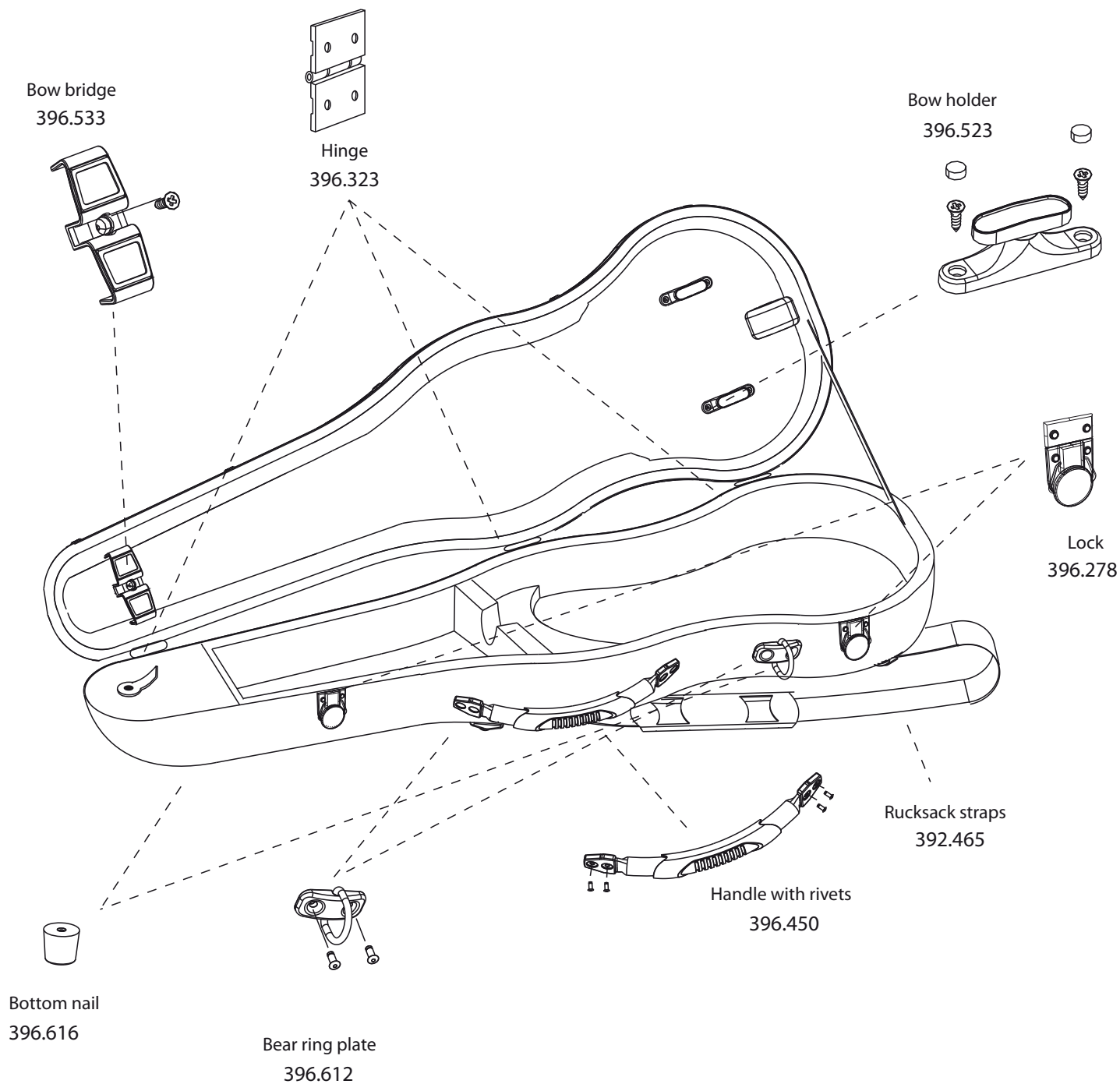

Not all parts included in delivery. Subject to change

GEWA Strings

GEWA Form shaped violin case Aspirante

- Styrofoam shell
- Padded suspension system
- Weight approx. 1,2 kg
- Water-repellent screw attached cover, carbon optics
- Small music sheet pocket, reflector strips, magnetic press buttons
- GEWA swivel-type holder patented, flexible bow holder
- blanket
- 2 sewn-on rucksack straps
- Address card compartment
- Indication of size at the bottom



300.101*	4/4
300.102*	3/4
300.103*	1/2
300.104*	1/4
300.105*	1/8
300.107*	1/16

The Bio I S series – the world is changing, what will we leave to our children? One really does not know.

But one thing is for sure: raw materials are becoming more scarce if we do not search for alternatives.

With our Bio series we are walking this way. The shell is made out of flax fibreboards, then lined and covered. This renewable material is also used in the automotive construction for the interior upholstery of doors, roof linings etc. Simple interior reduced to the essential. Very low weight.

GEWA Form shaped violin case Bio I S

- Organic flax shell
- Padded suspension system
- Weight approx. 1,6 kg
- Soft handle
- GEWA patented swivel type holder for 2 bows
- Accessory compartment
- 2 detachable rucksack straps
- Exterior brown
- Interior velvet beige

- Exterior grey
- Interior velvet black



300.111*	4/4
----------	-----

300.121*	4/4
----------	-----

GEWA Strings

GEWA Form shaped violin case Liuteria Concerto

300.801 - 300.807

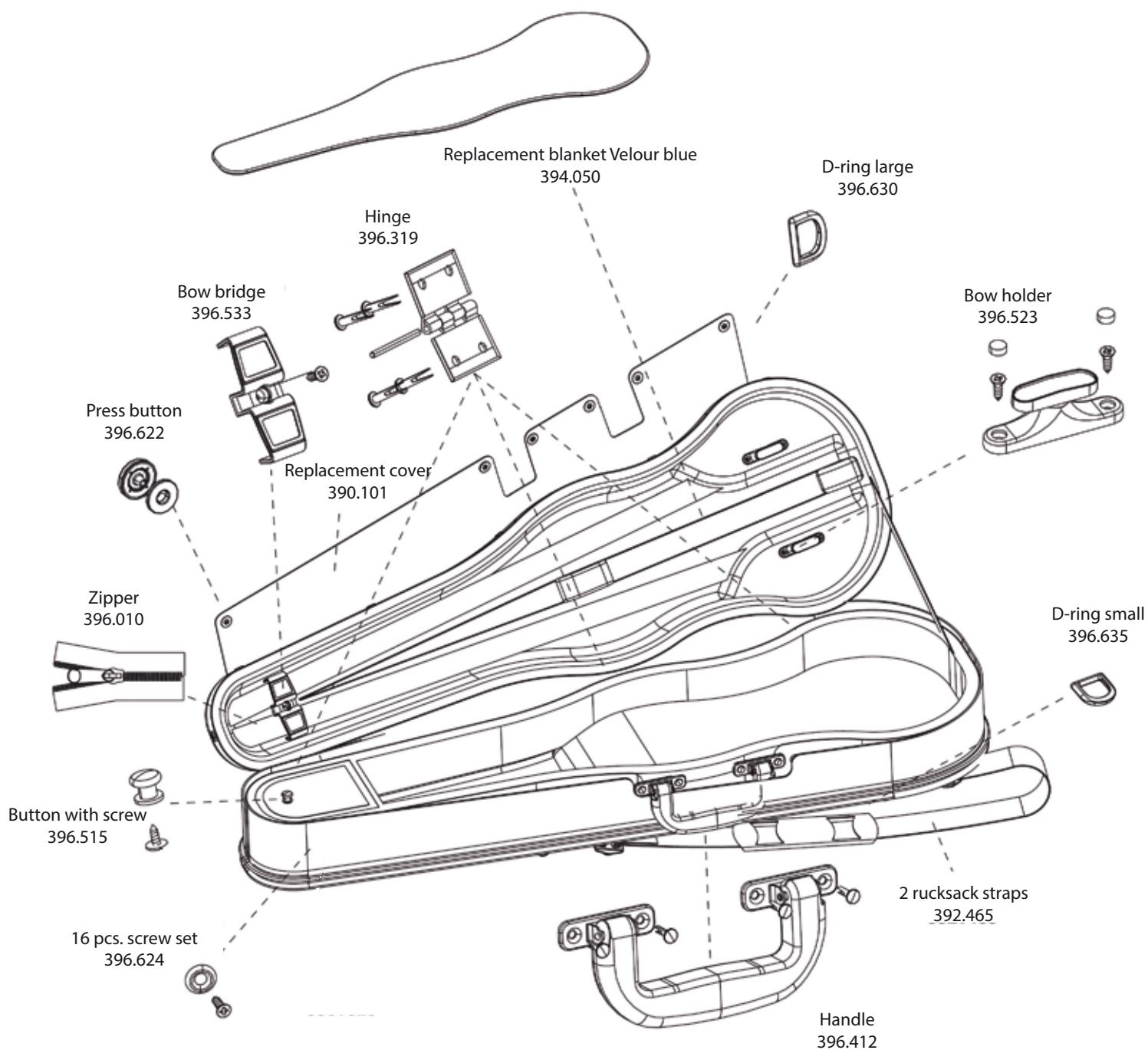

Not all parts included in delivery. Subject to change

GEWA Strings

The Concerto series- the entry into the classic violin case production. The ideal, well-priced case for students and beginners. Thermal shell, equipped with all necessities, quality GEWA components with screw-attached, sturdy cover. Medium weight.

GEWA Form shaped violin case Liuteria Concerto

- Thermo shell
- Padded suspension system
- Weight ca. 2,0 kg
- Water-repellent screw-attached cover
- GEWA swivel type holder pat.
- Flexible bow holder
- Protection blanket
- Accessory compartment
- 2 detachable rucksack straps
- Exterior Tex black
- Interior velour blue



300.801*	4/4
300.802*	3/4
300.803*	1/2
300.804*	1/4
300.805*	1/8
300.807*	1/16

GEWA Rucksack for form shaped violin cases SPS

- Practical rucksack bag
- DE LUXE version
- Fits GEWA form shaped violin cases
- 10 mm foam padding
- Large accessory pocket
- 2 quick stow rucksack straps
- GEWA-Tex



300.850*	Violin Black
300.851*	Violin Blue

- Fits also Strato form shaped violin cases

300.860*	Viola Black
----------	-------------

GEWA Rucksack for violin case Idea / Air

- Useful music sheet pocket with rucksack fixture
- DE LUXE version
- Fits GEWA Idea and Air violin cases
- Well-padded rucksack straps, can be stowed away
- Specifically designed back cushion
- Large accessory pocket with organizer
- Side pocket for music stand
- GEWA-Tex



300.870*

GEWA Silk bag for violin Classic

- Protects instrument inside the case
- Viscose silk
- 4/4 Size



300.880*	Brown
300.881*	Bordeaux
300.882*	Natural

301.510 - 301.540

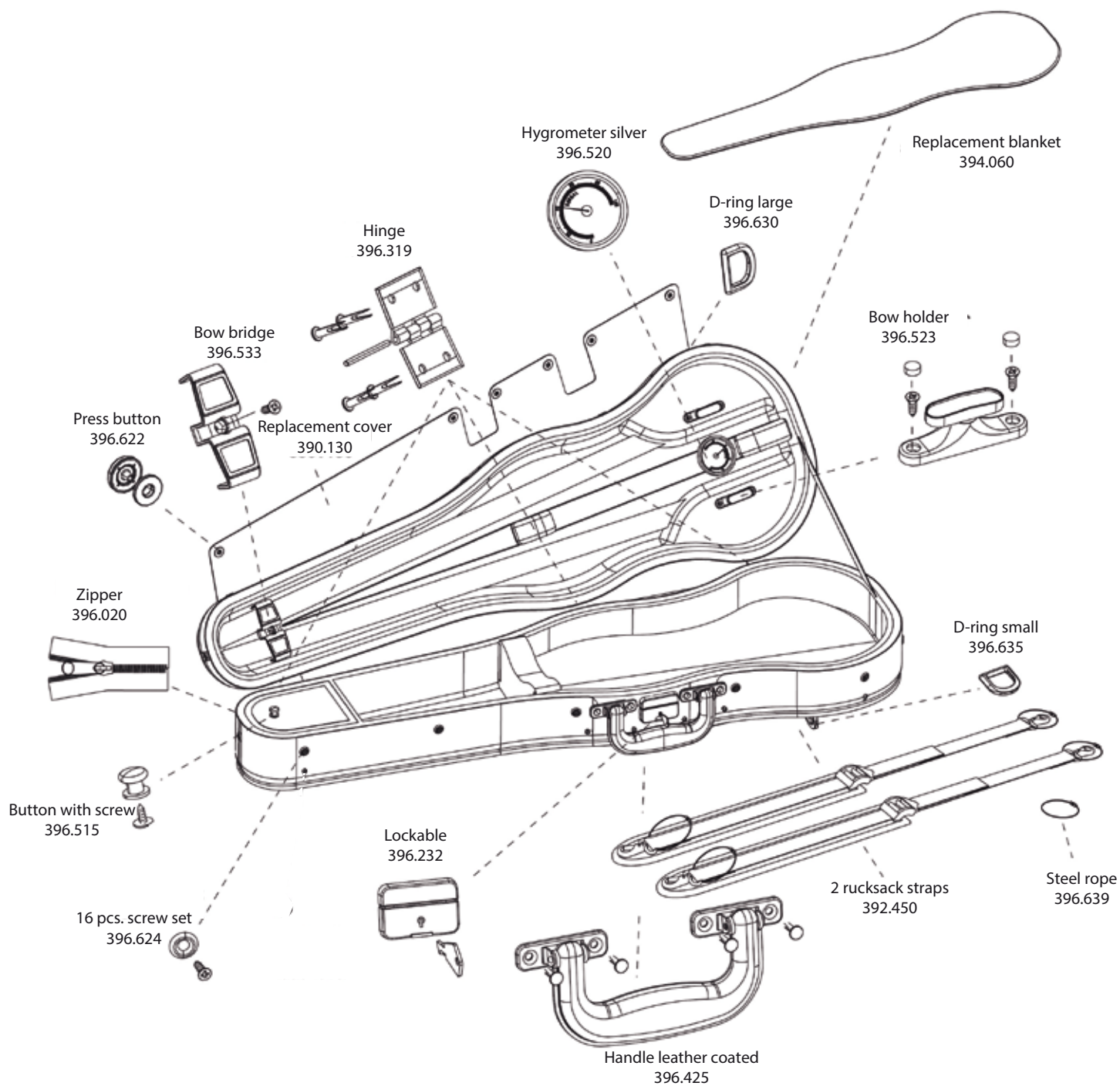

Not all parts included in delivery. Subject to change

GEWA Strings

The Maestro series - the next step for dedicated musicians and students. Thermo shell based on the legendary JAEGER shape. High-quality materials and components, e.g. Swiss lock. Medium weight.

GEWA Form shaped violin case Liuteria Maestro

- Thermo shell
- Padded suspension system
- Weight ca. 2,0 kg
- **Water-repellent, screw-attached cover**
- GEWA swivel-type holder patented, flexible bow holder
- Swiss lock
- Protection blanket
- Accessory compartment
- Leather handle
- 2 detachable 40 mm wide Neoprene rucksack straps

- Exterior Tex black
- Interior plush red



301.510* 4/4

- Exterior Tex black
- Interior plush blue

- Exterior Tex black
- Plush green interior



301.530* 4/4

- Exterior Tex blue
- Interior plush grey



301.520* 4/4

301.521* 3/4

301.522* 1/2



301.540* 4/4

303.210 - 303.420

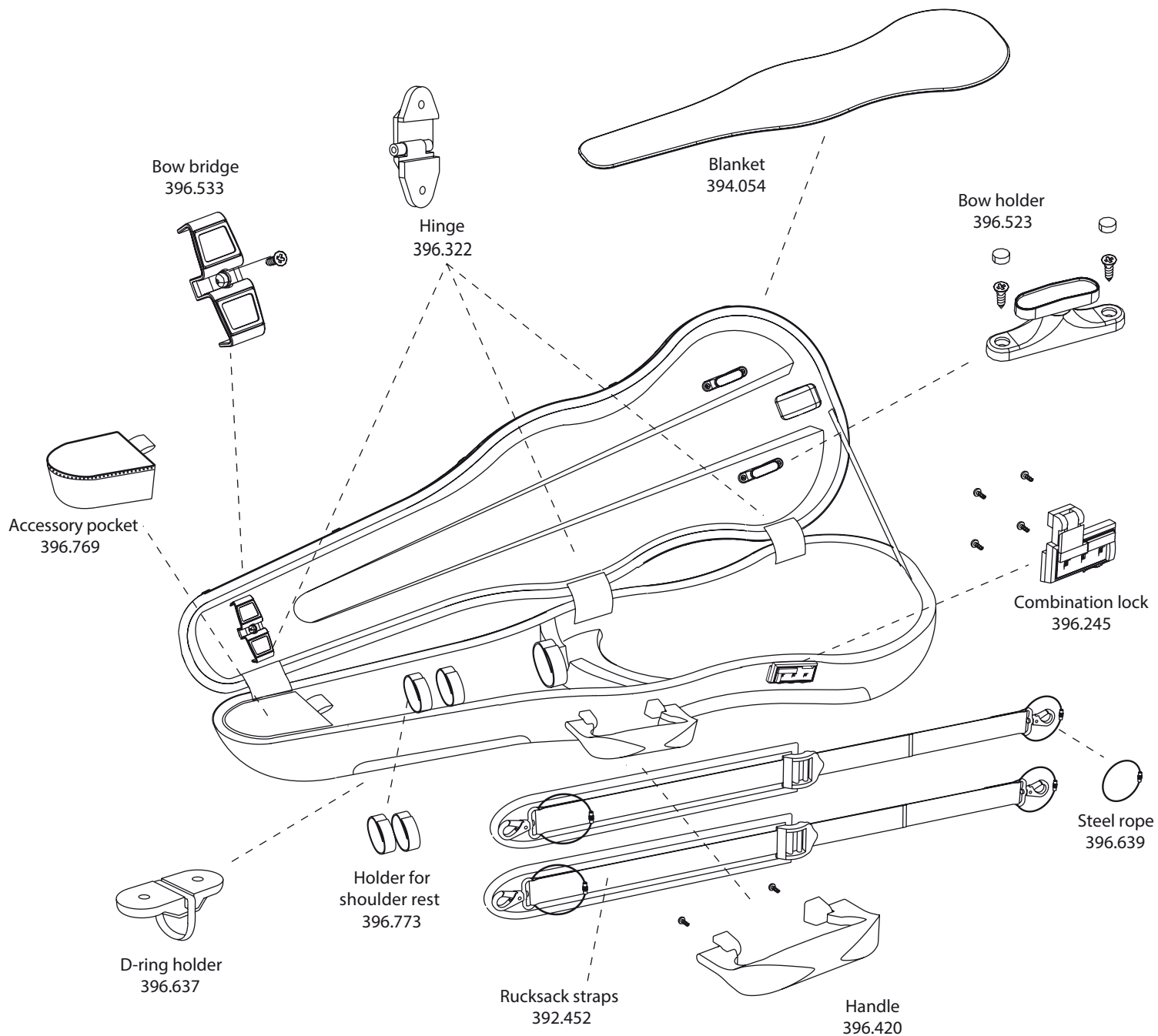

Not all parts included in delivery. Subject to change

GEWA Strings

The Air series - the next generation of cases. Based on the Idea concept, this novel manufacturing technology allows for the production of low-cost cases with similar mechanical features, very good insulation characteristics. Tasteful shape with scratch-resistant surface. Very low weight.

GEWA Form shaped violin cases Air 1.7

- Made in Germany
- Specially developed thermoplast-shell
- Extremely high break-resistance
- Weight approx. 1.7 kg without accessories
- Outstanding isolation characteristics, only 0.025 W/mK thermal conductivity
- Light but still gives optimum protection
- Padded suspension system
- GEWA patented swivel type holder and flexible bow holder
- Useful, detachable accessory pocket
- 2 detachable neoprene rucksack straps for supreme carrying comfort
- Inside black velour padding, protection blanket
- Combination lock



GERMAN
DESIGN
AWARD
SPECIAL
2016



reddot award 2014
winner

GEWA *Air*



303.210	Black high gloss
303.220	grey highgloss
303.230	Red highgloss
303.240	White high gloss
303.250	beige high gloss
303.260	orange highgloss
303.270	brown highgloss

303.280	purple high gloss
303.290	Blue highgloss
303.310	Black matt
303.340	White matt
303.410	black metallic high gloss
303.420	Silver metallic high gloss

303.620 - 303.680

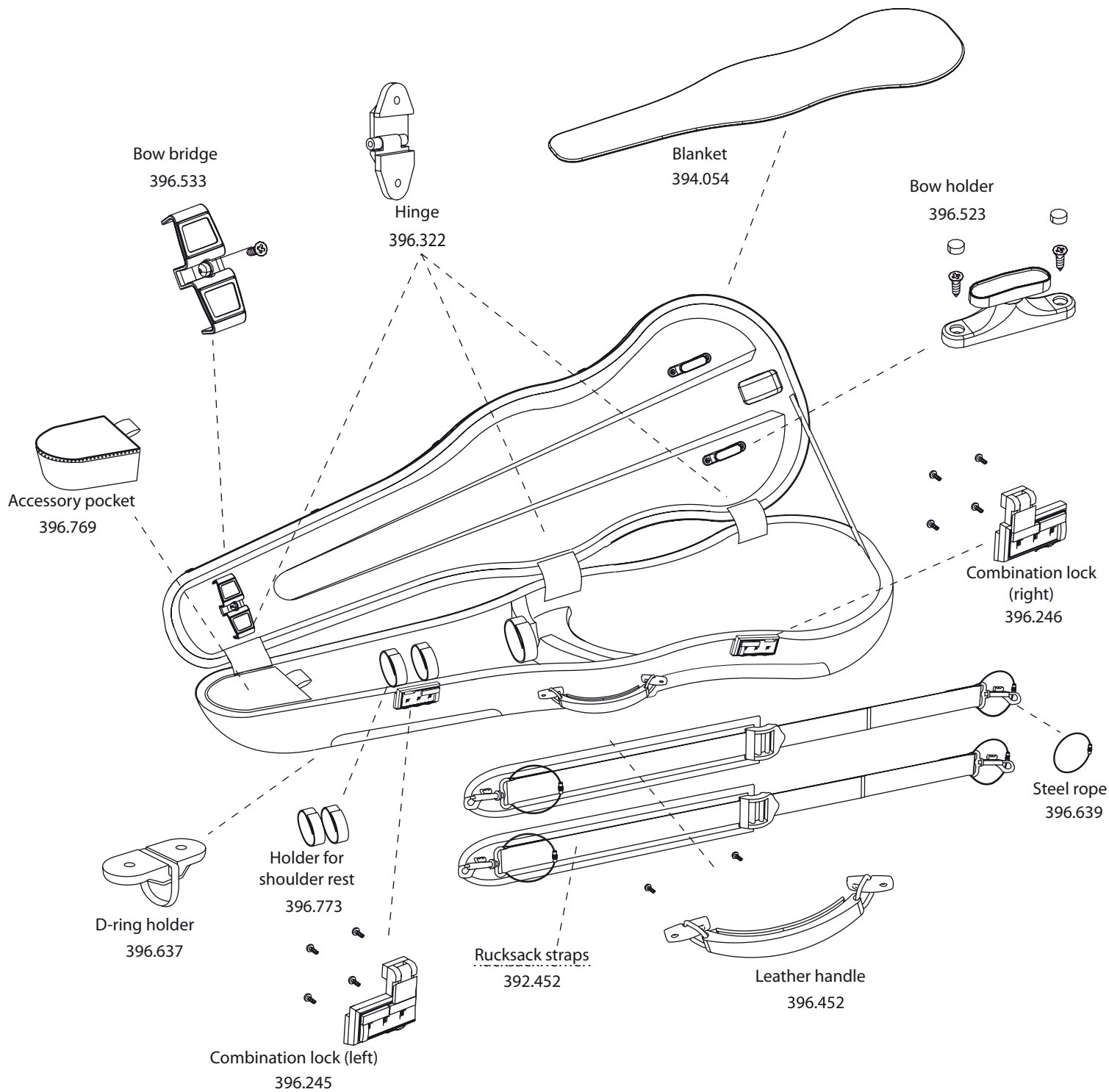

Not all parts included in delivery. Subject to change

GEWA Strings

With the **GEWA Air Prestige** you will get the classiest Air violin case of all. The superior leather-look in four current colors appeals to many people. The matching colored leather handles gives the case a special feature. Light –sturdy – well isolated, the extraordinary features of the Air Technology protect your violin. GEWA Air Prestige is available as a formed or oblong case. The label „Made in Germany“ not only represents that the GEWA Air Prestige case is made in Germany, but it is also made by our experienced staff in our factory in Adorf/Vogtland.

GEWA Form shaped violin cases Air Prestige

- **Made in Germany**
- **Especially developed Thermoplast shell**
- **Extremely high break resistance**
- **Weight ca. 1,9 kg without accessories**
- **Outstanding isolation characteristics, only 0,025 W/mK thermal conductivity**
- **Hand-sewn leather handle**
- **Lid in leather-look**
- Padded suspension system
- GEWA patented swivel-type bow holder and flexible bow bridge
- Functional, removable accessory pocket
- 2 detachable Neoprene rucksack straps for high wearing comfort
- Inside: black velour padding, protection blanket
- Combination lock

GEWA *Air*



303.620	Grey/black
303.630	Red/black
303.650	Cappuccino/black
303.680	Purple/black

309.111 - 300.122

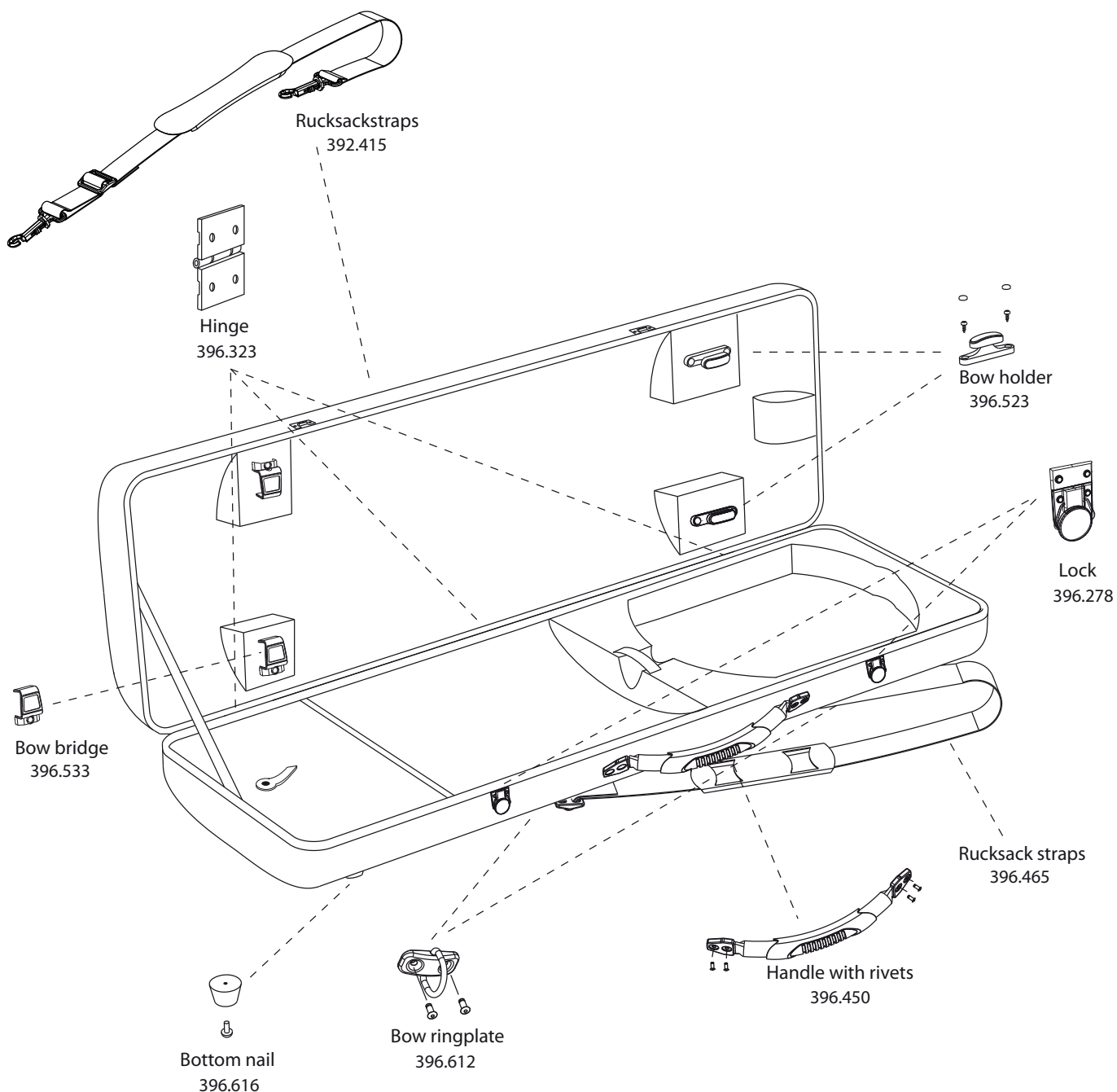

GEWA Strings

The case for every beginner and student. Styrofoam-shell, equipped with all necessary components, quality GEWA assemblies, screw attached cover with Carbon trimmings.

GEWA Violin case Aspirante

- Styrofoam shell
- Padded suspension system
- Weight approx. 1,7 kg
- Water-repellent screw attached cover, carbon optics
- Music sheet pocket, reflector strips, magnetic press buttons
- GEWA swivel-type holder patented, flexible bow holder
- blanket
- 2 detachable rucksack straps
- Address card compartment
- Indication of size at the bottom



309.101*	4/4
309.102*	3/4
309.103*	1/2
309.104*	1/4
309.105*	1/8
309.107*	1/16

The Bio I S series – the world is changing, what will we leave to our children? One really does not know.

But one thing is for sure: raw materials are becoming more scarce if we do not search for alternatives. With our Bio series we are walking this way. The shell is made out of flax fibreboards, then lined and covered. This renewable material is also used in the automotive construction for the interior upholstery of doors, roof linings etc. Simple interior reduced to the essential.

Very low weight.

GEWA Violin case Bio I S

- Organic flax shell
- Padded suspension system
- Weight ca. 2,3 kg
- Soft handle
- GEWA swivel type holder for 2 bows
- Accessory compartment
- 2 detachable rucksack straps



- Exterior brown
- Interior velvet beige

- Exterior grey
- Interior velvet black



309.111* 4/4

- **With music sheet pocket and side handle**
- Exterior brown
- Interior velvet beige

309.121* 4/4

- **With music sheet pocket and side handle**
- Exterior grey
- Interior velvet black



309.112* 4/4

309.122* 4/4

309.225

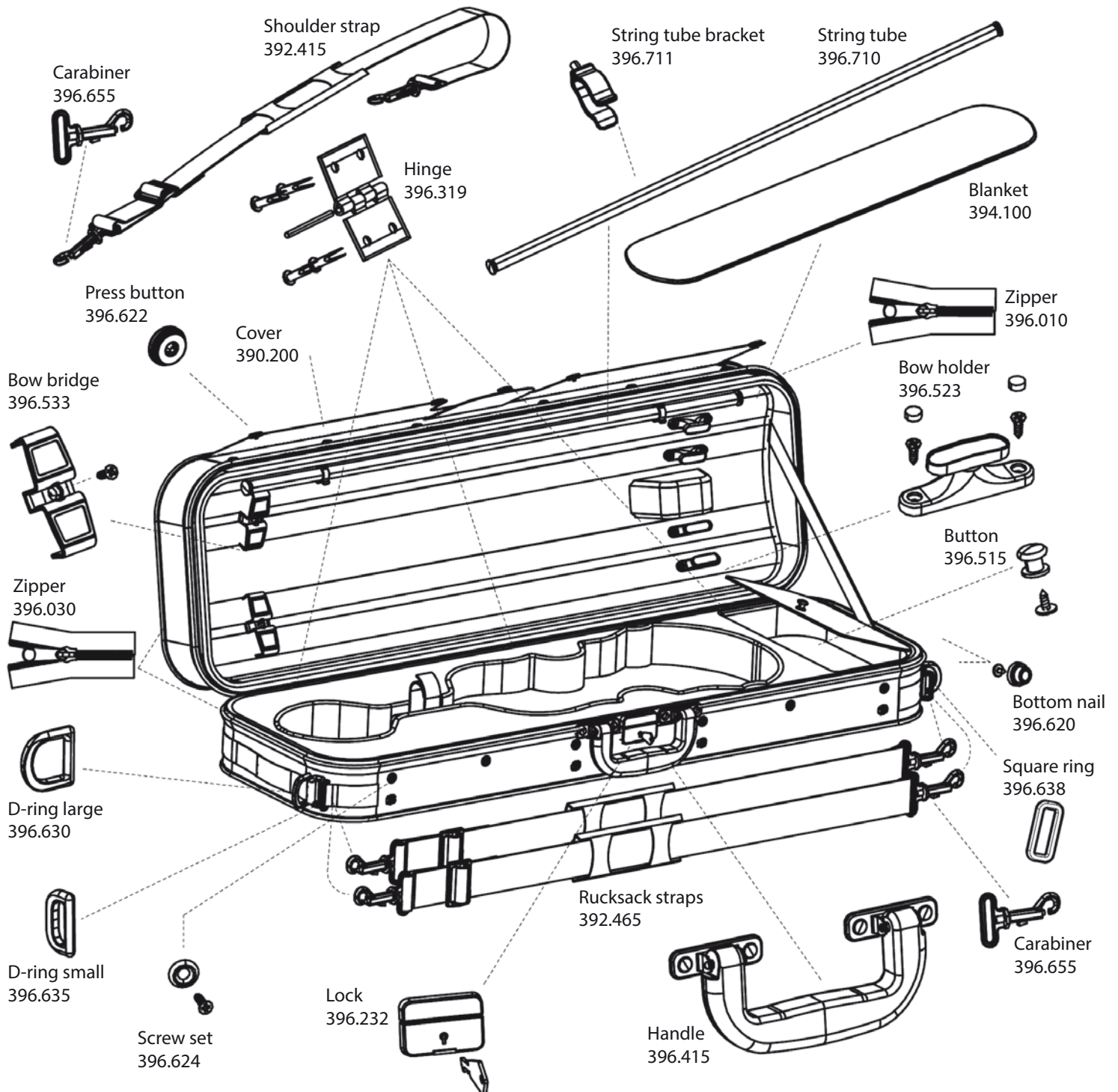

GEWA Strings

The Concerto series- the entry into the classic violin case production.

The ideal, well-priced case for students and beginners. Thermal shell, equipped with all necessities, quality GEWA components with screw-attached, sturdy cover.

Medium weight

GEWA Violin case **Liuteria Concerto**

- Thermo shell
- Padded suspension system
- Weight ca. 2.9 kg
- Water-repellent screw-attached cover with music sheet pocket
- GEWA swivel type holder pat.
- Flexible bow holder
- Swiss lock
- Protection blanket
- Accessory compartment
- 2 detachable rucksack straps
- Exterior Tex black
- Interior velour blue



309.225* 4/4

- Thermo shell
- Padded suspension system
- Weight ca. 2.9 kg
- Water-repellent screw-attached cover with music sheet pocket
- GEWA swivel type holder pat.
- Flexible bow holder
- Swiss lock
- Protection blanket
- Accessory compartment
- Leather handle
- 2 detachable rucksack straps
- Exterior Tex black
- Interior diamond pattern plush red

- Interior diamond pattern plush blue



309.300* 4/4



309.305* 4/4

309.360 – 309.364

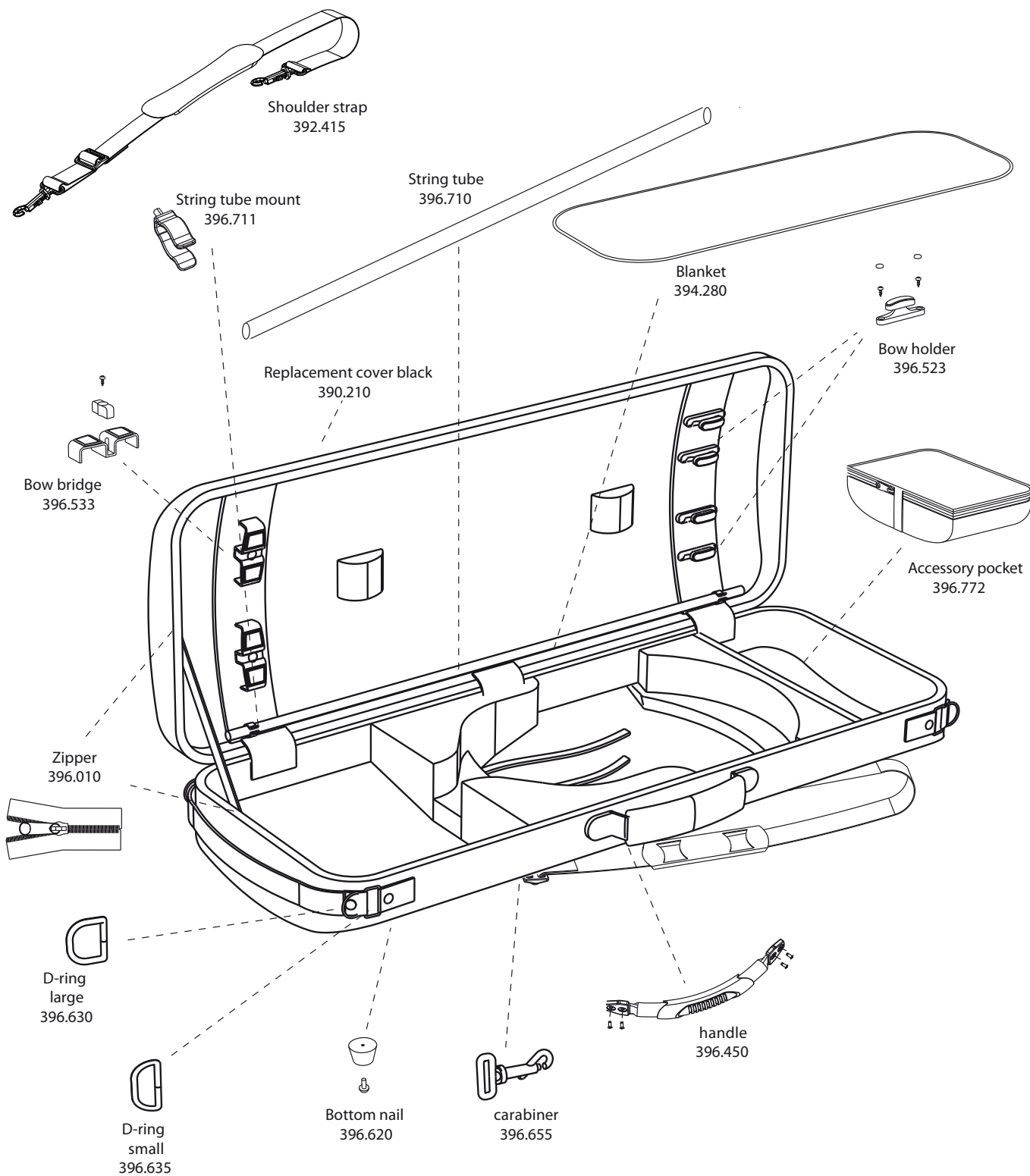

GEWA Strings

Made in traditional wooden construction, the model GEWA Oxford is an absolute classic. Its elegant shape, slim and rounded, speaks for itself and meets all requirements. With its elementary black interior and the removable accessory compartment, the traditional outer shell is complemented by modern details.

This violin case was devised by our Saxon development team and is perfect for musicians and students that put great emphasis on break resistance and good insulation. Inside you find sufficient space for 4 bows, accessory pocket, shoulder rest and other equipment. The detachable rucksack fittings, the side handle as well as the soft handle offer an excellent wearing comfort for all occasions. With the violin case Oxford you own a solid violin case. Medium weight.

GEWA Violin case Oxford

- **Wooden shell**
- Padded suspension system
- Weight ca. 2,4 kg without accessories
- Water-repellent, screw-attached cover with music sheet pocket
- GEWA swivel-type holder, patented
- Flexible bow holder
- **Useful, removable accessory bag**
- 2 detachable rucksack straps
- Inside black warp pile velvet



309.360* Exterior black



309.364* Outside brown

310.601

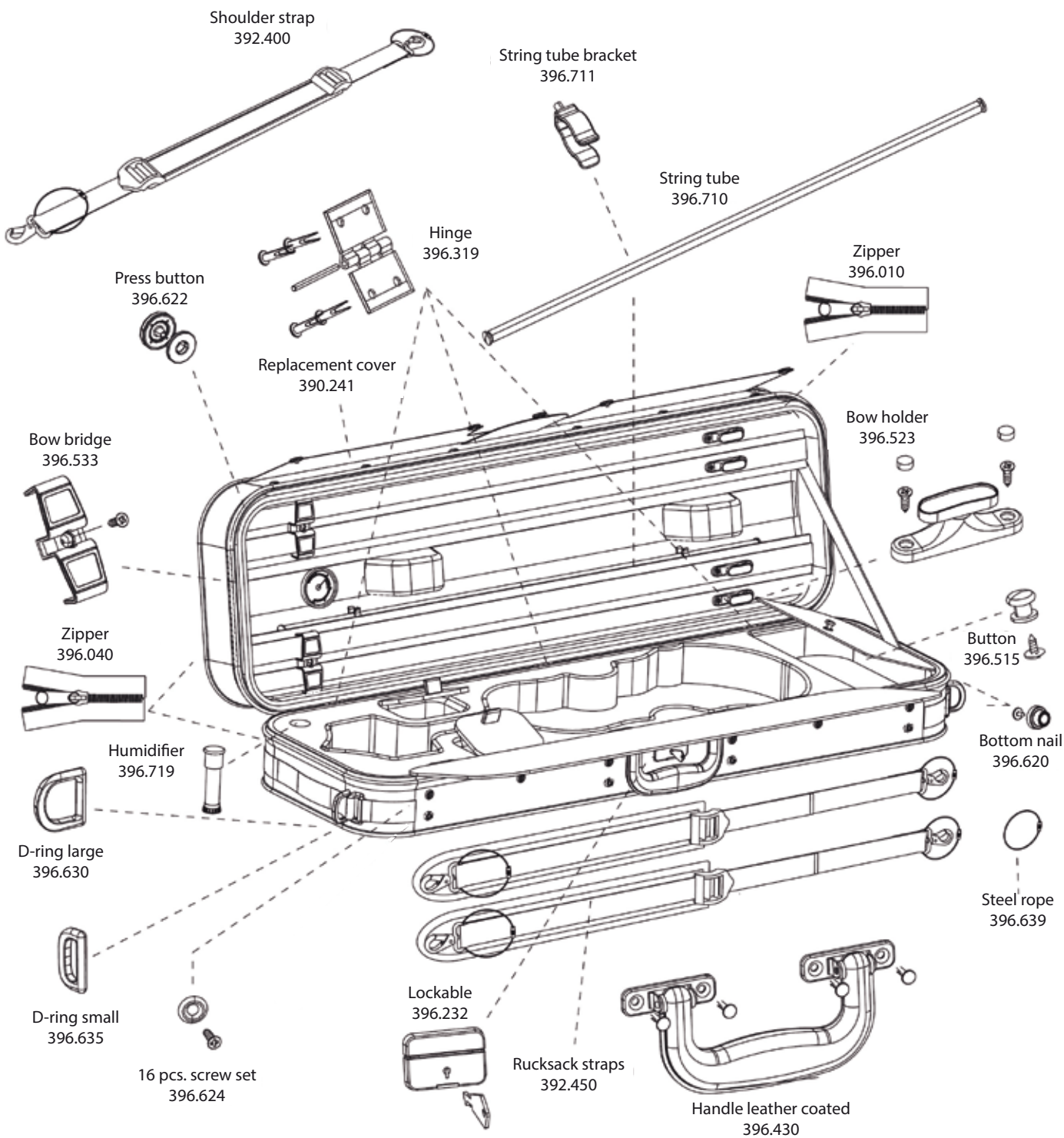

Not all parts included in delivery. Subject to change

GEWA Strings

The Venetia case was derived from the Maestro model for musicians who love the Italian design. The case charms you with its unique interior look. Medium weight.

GEWA Violin case Liuteria Venetian

- Thermo shell
- Padded suspension system
- Weight ca. 2.9 kg
- Water-repellent screw-attached cover with music sheet pocket
- GEWA swivel type holder pat.
- Flexible bow holder
- Swiss lock
- Protection blanket
- Accessory compartments
- Leather handle
- 2 detachable Neoprene rucksack straps
- Exterior Tex black
- Interior plush ocean darkblue



310.601* 4/4

309.510 – 309.540

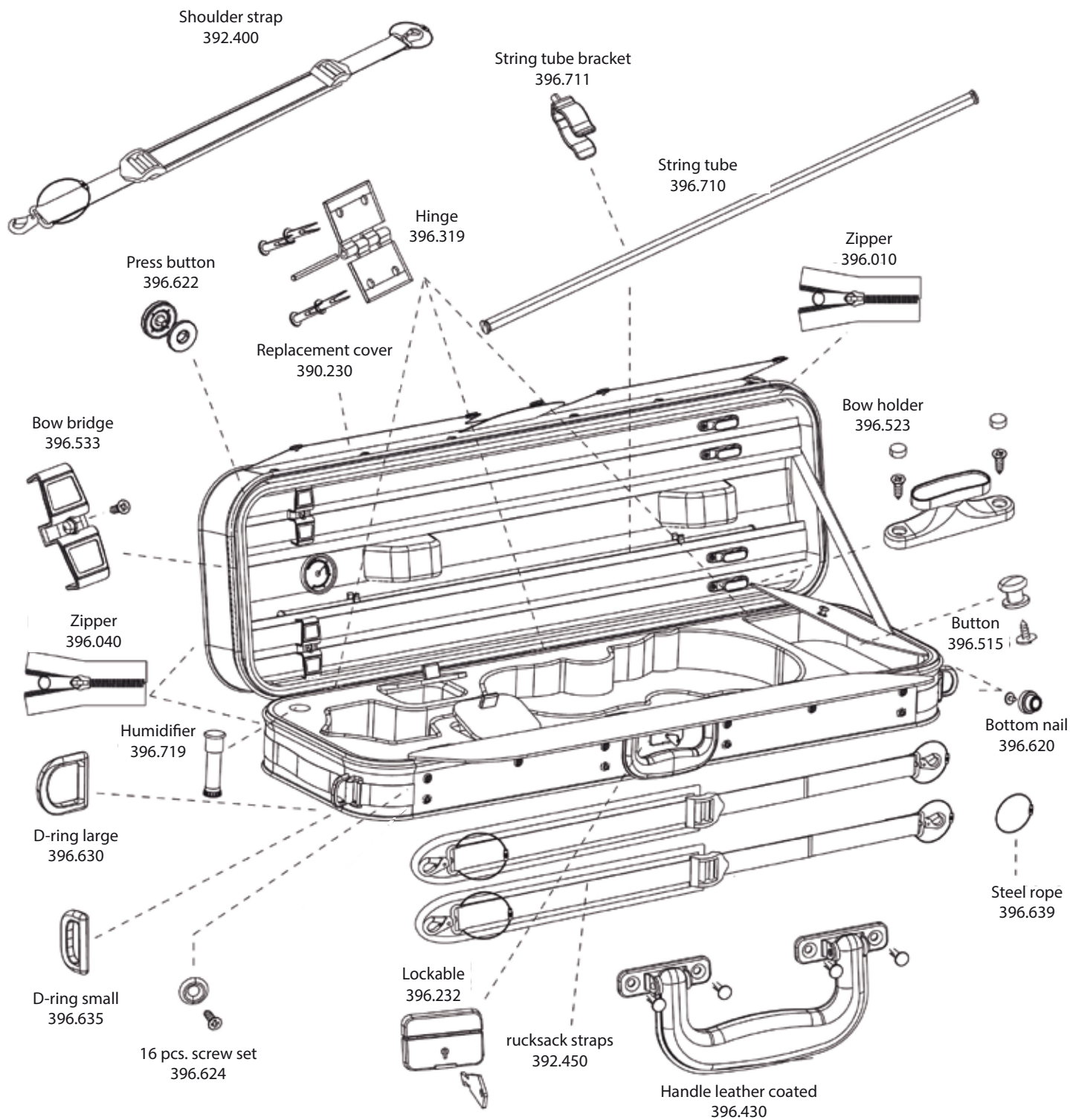

Not all parts included in delivery. Subject to change

GEWA Strings

The Maestro series - the next step for dedicated musicians and students. Thermo shell based on the legendary JAEGER shape. High-quality materials and components, e.g. Swiss lock. Medium weight.

GEWA Violin case Liuteria Maestro

- Thermo shell
- Padded suspension system
- Weight ca. 2.8 kg
- Water-repellent screw-attached cover with music sheet pocket
- GEWA swivel type holder pat.
- Flexible bow holder
- Swiss lock
- Protection blanket
- Accessory compartments
- Leather handle
- 2 detachable Neoprene rucksack straps

- Exterior Tex black
- Interior plush burgundy

- Exterior Tex black
- Interior plush green



309.510* 4/4

- Exterior Tex black
- Interior plush blue



309.530* 4/4

- Exterior Tex blue
- Interior plush anthracite



309.520* 4/4



309.540* 4/4

311.500 – 311.806

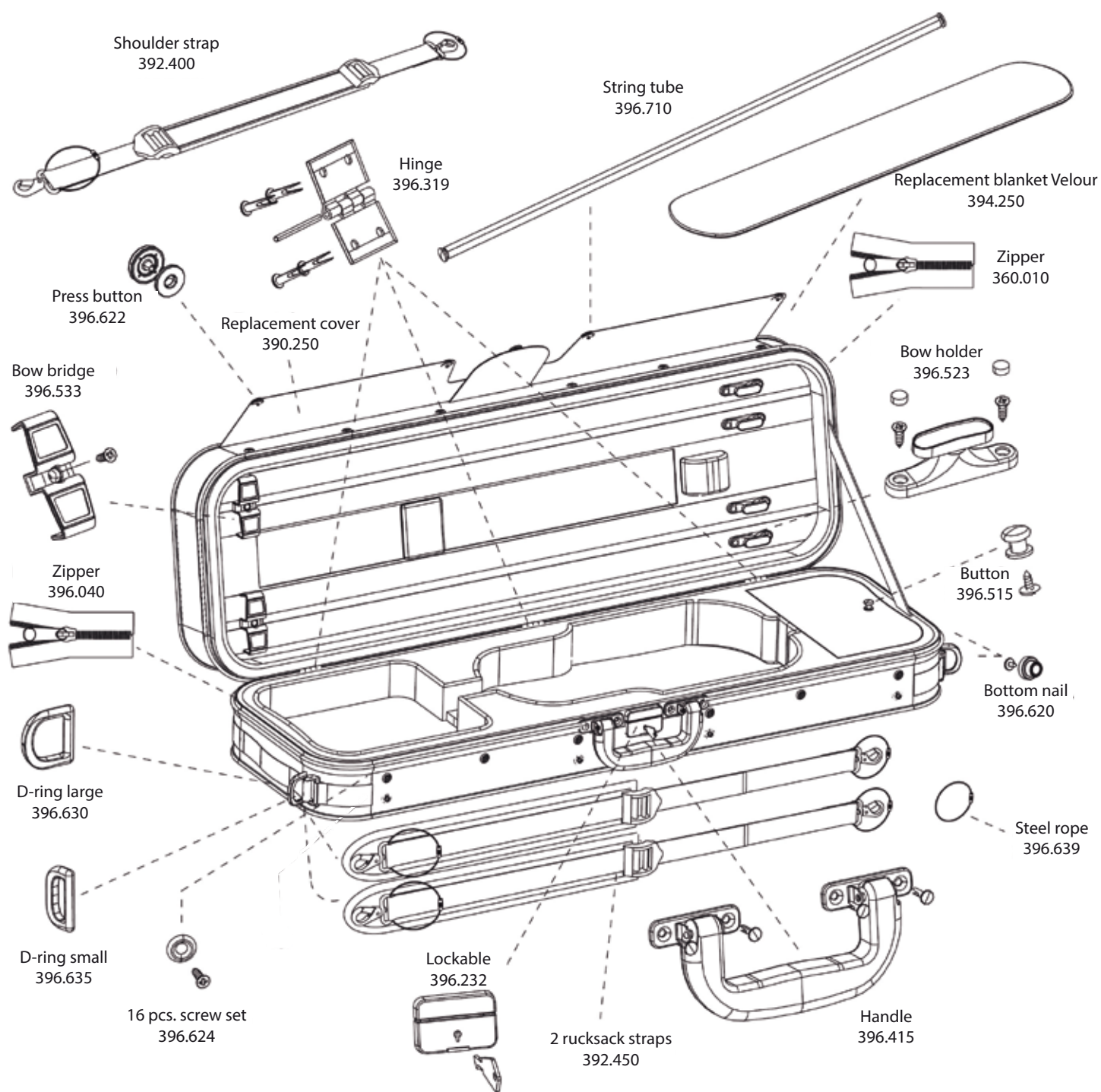

GEWA Strings

The Strato series – the workhorse amongst the GEWA cases.

This is the case for orchestra musicians, instructors, teachers that want their instrument protected by all means and who travel a lot. Light, sturdy, functional. Polyfoam shell with wooden frame, exchangeable cover, rucksack fittings and high-quality, resilient materials.

GEWA Violin case Strato

- **Made in Germany**
- High density polyfoam shell
- Padded suspension system
- **Ultra light, ca 1,9 kg**
- **Water-repellent replacement cover with music sheet pocket**
- GEWA swivel-type holder patented, flexible bow holder
- Swiss lock
- Protection blanket
- Accessory compartment
- 2 detachable Neoprene rucksack straps
- Exterior Tex black
- Interior velour dark blue



311.500 4/4

- Exterior Tex dark blue
- Inside velour anthracite



311.502 4/4

- Exterior Tex dark brown
- Interior velour beige



311.504 4/4

The Strato De Luxe series – If orchestra musicians, instructors and teachers place more emphasis on the interior padding, they opt for the more high-grade model of the Strato case. The specially selected velvet plush makes the case classy. It is still light, professionally equipped with GEWA quality components and a robust, screw-attached cover with sheet music pocket.

GEWA Violin case Strato De Luxe

- Made in Germany
- High density polyfoam shell
- Padded suspension system
- **ultralight, approx. 2,2 kg**
- Screw attached cover with music sheet pocket, water repellent
- GEWA swivel type holder patented
- flexible bow holder
- Blanket
- Accessory compartment
- 2 Detachable Neoprene rucksack straps
- Exterior Tex black
- Interior velvet plush burgundy



311.800 4/4

- Exterior Tex black
- Interior velvet plush dark blue



311.802 4/4

- Exterior Tex dark blue
- Interior velvet plush silver



311.804 4/4

- Exterior Tex dark brown
- Interior velvet plush green



311.806 4/4

316.210 - 316.420

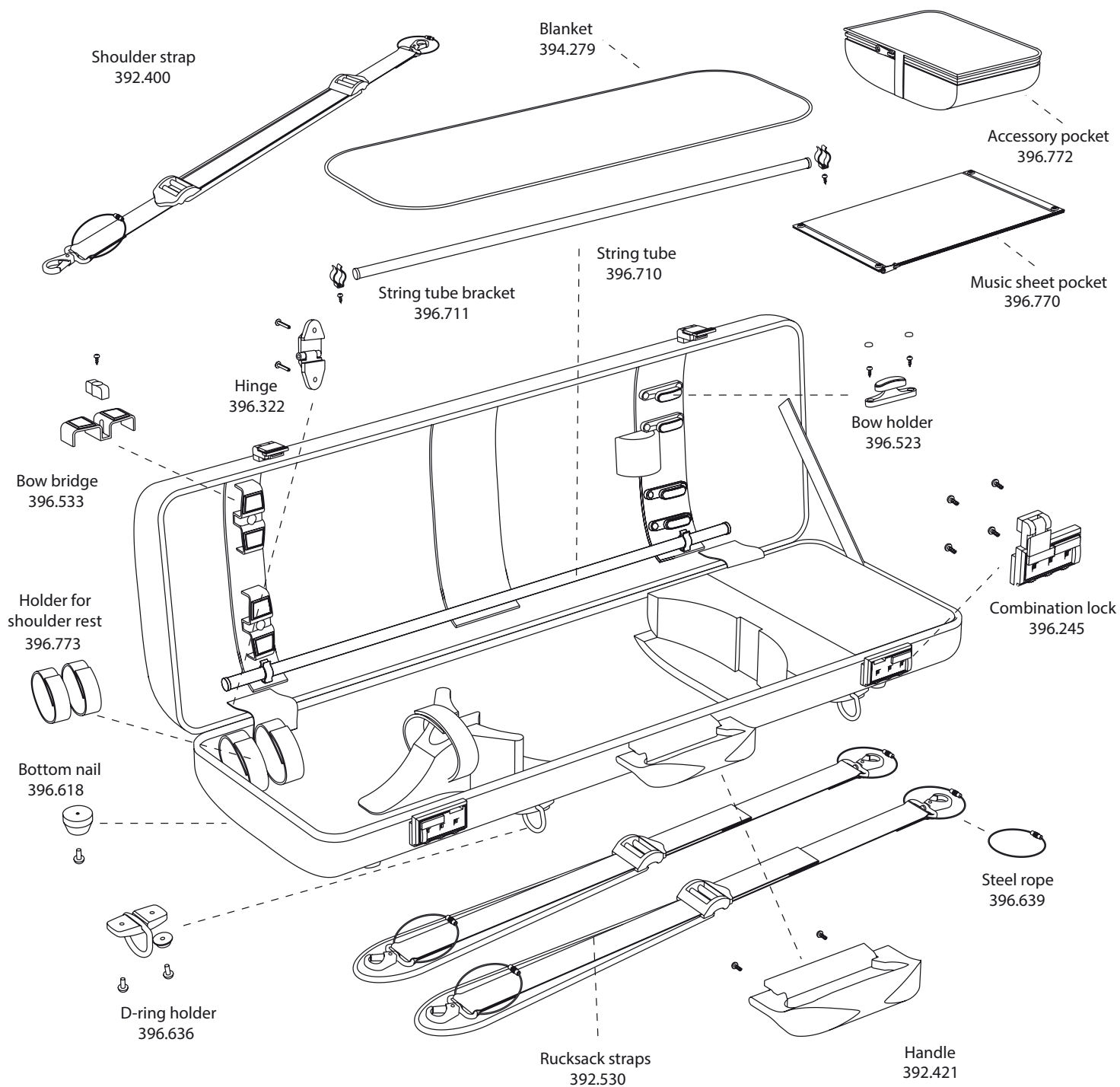

GEWA Strings

The Air series - the next generation of cases. Based on the Idea concept, this novel manufacturing technology allows for the production of low-cost cases with similar mechanical features, very good insulation characteristics. Tasteful shape with scratch-resistant surface. Very low weight.

GEWA Violin case Air 2.1

- Made in Germany
- Specially developed thermoplast-shell
- Extremely high break-resistance
- Weight approx. 2,1 kg without accessories
- Outstanding isolation characteristics
- Light, but nevertheless optimum protection
- Padded suspension system
- GEWA patented swivel type holder and flexible bow holder
- Functional, detachable accessory pocket
- 2 detachable Neoprene rucksack straps for high wearing comfort
- Inside black velour padding, protection blanket
- Combination lock
- Attached music sheet pocket
- Optional with side handle

GEWA
Air



316.210	Black high gloss
316.220	grey highgloss
316.230	Red highgloss
316.240	White high gloss
316.250	beige high gloss
316.260	orange highgloss
316.270	brown highgloss

316.280	Purple high gloss
316.290	Blue highgloss
316.310	Black matt
316.340	White matt
316.410	black metallic high gloss
316.420	Silver metallic high gloss

316.495

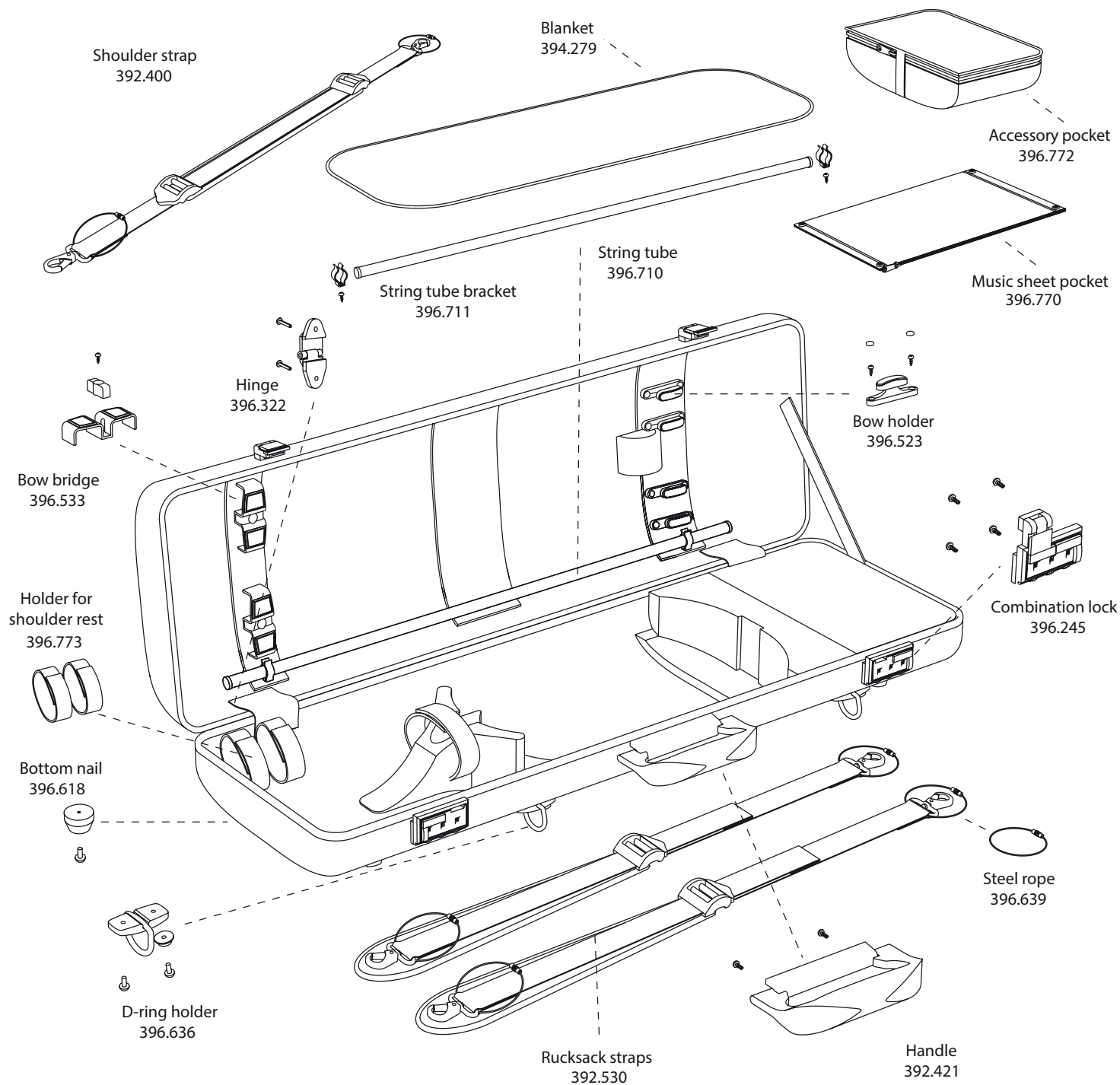



- Ray Chen is touring with the Air Case by GEWA. The Australian-Taiwanese violinist carries his Stradivari violin in the new Air violin case. While travelling Australia to New York he passes quite some climate zones and is convinced of the new Air case with its special isolation characteristics. GEWA music proudly presents the exclusive special edition of the Air series „Ray Chen Signature“. This model is available now with limited quantities.

- Made in Germany
- Specially developed thermoplast-shell
- Extremely high break-resistance
- Weight approx. 2,1 kg without accessories
- Outstanding isolation characteristics
- Light, but nevertheless optimum protection
- Padded suspension system
- GEWA patented swivel type holder and flexible bow holder
- Functional, detachable accessory pocket
- 2 detachable Neoprene rucksack straps for high wearing comfort
- Inside black velour padding, protection blanket
- Combination lock
- Attached music sheet pocket
- Optional with side handle



316.500

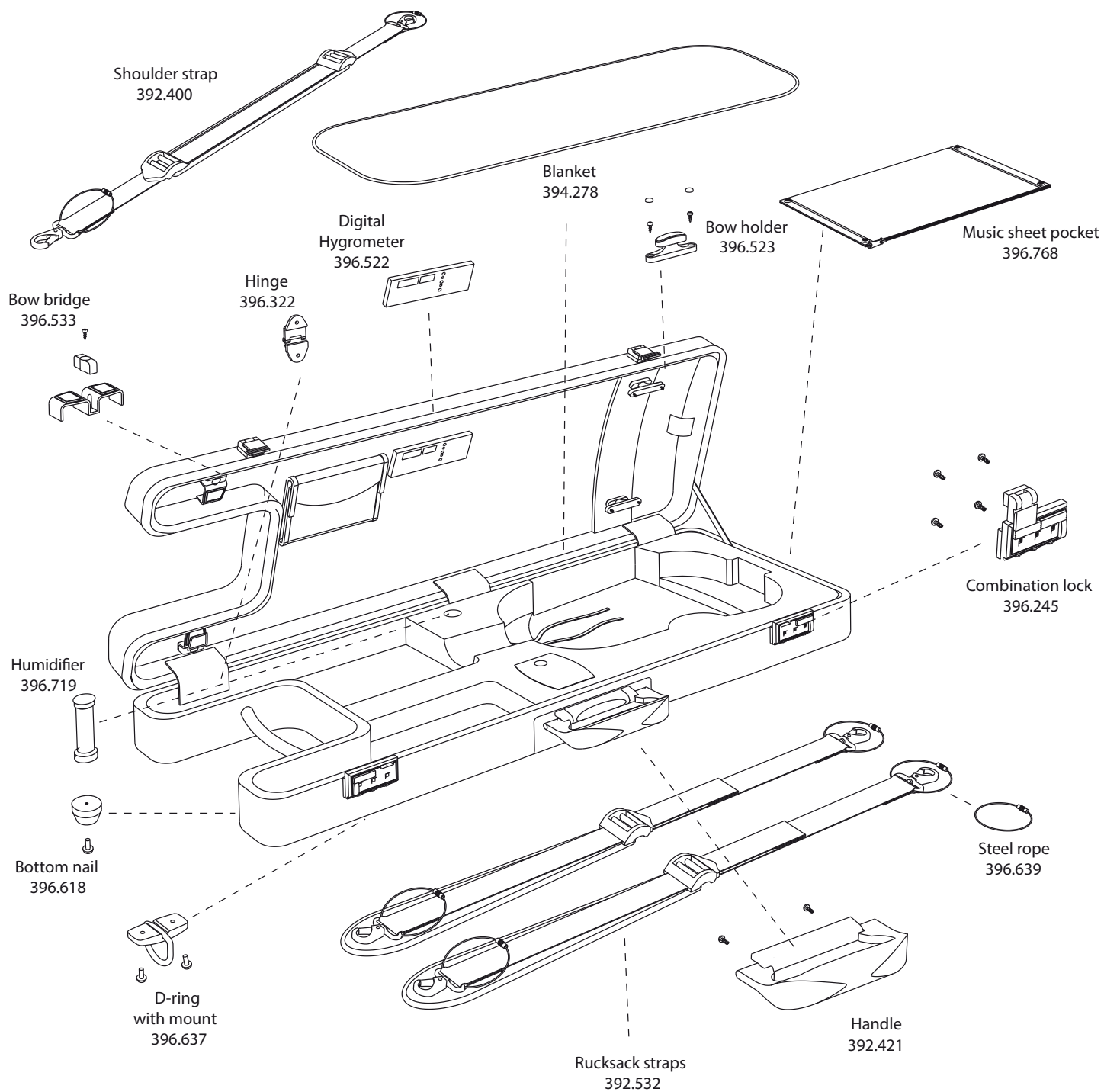

GEWA Strings

The Air series – the new, revolutionary GEWA violin concept – handmade in Germany.

With the Air Ergo we launch a revolutionary violin case. Its handles and the mouldings of the case shell are adapted to the human body and common carrying habits. Air Ergo means headroom, room towards the ground and secure hold. The new Air shell technology ensures lightness, but at the same time optimum protection. Stability by its extremely high break resistance and outstanding insulation qualities.

GEWA Violin case Air Ergo

- Made in Germany
- Especially developed thermoplast shell
- Weight ca. 2.4 kg without accessories
- Extremely high break resistance
- Great insulation characteristics
- Padded suspension system
- GEWA swivel-type holder pat. and flexible bow holder for two bows
- Detachable accessory pouch, attached music sheet pocket
- Large compartment for shoulder rest
- Protection blanket, sturdy side handle
- Combination lock, digital hygrometer, humidifier
- Detachable Neoprene rucksack straps worn crosswise
- International proprietary right - Developed in cooperation with Rainer Wilke
- White/Bordeaux



2 abnehmbare Neopren Rucksackriemen für hohen Tragekomfort

2 detachable Neoprene rucksack straps for comfortable carrying



Praktische herausnehmbare Zubehörtasche, aufgesetzte Notentasche
 Practical detachable accessory pocket, attached music sheet pocket



Kopffreiheit
 Headroom

GEWA Strings

GEWA Violin case Air Prestige

316.620 – 316.680

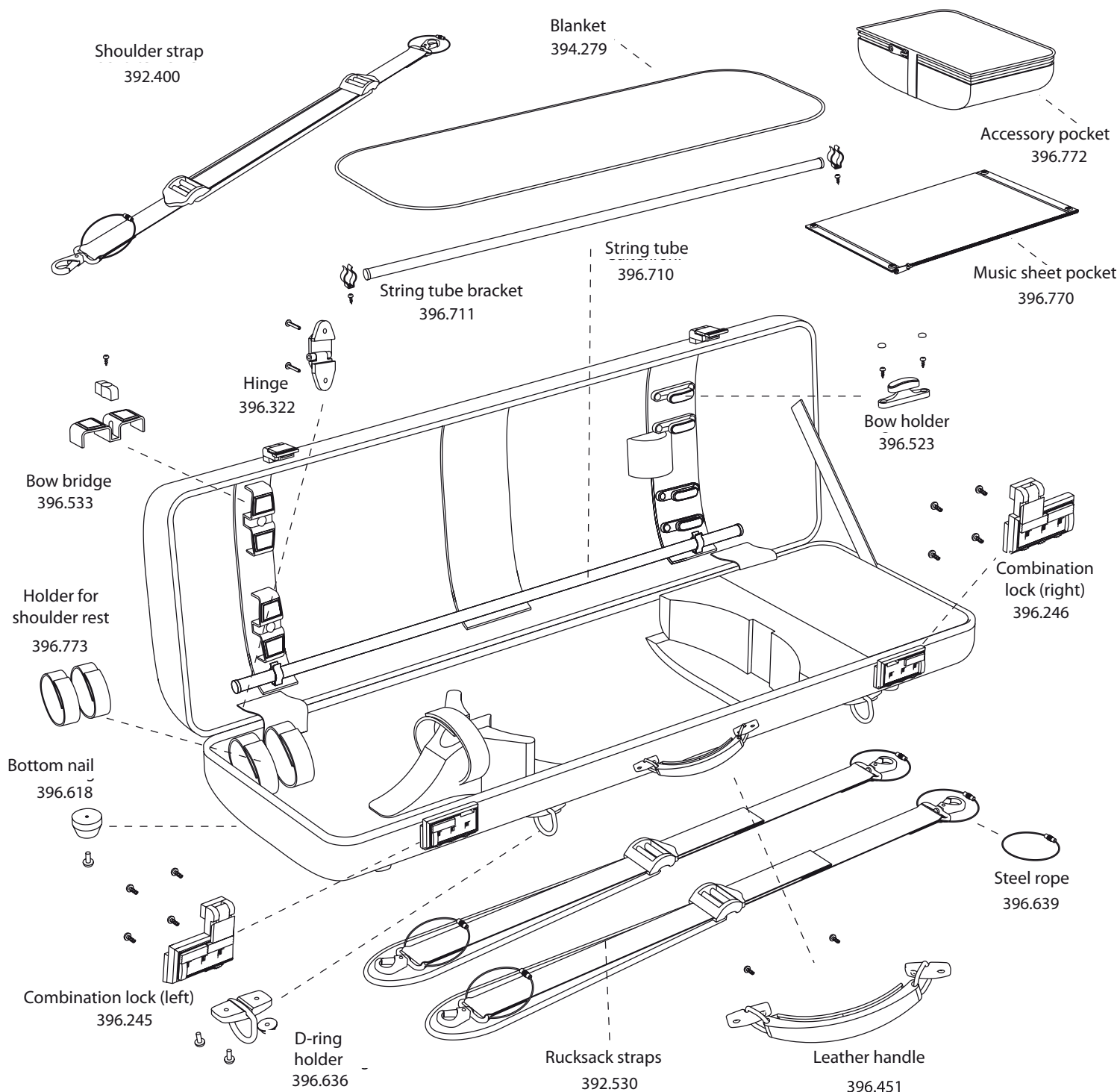

Not all parts included in delivery. Subject to change

GEWA Strings

With the **GEWA Air Prestige** you will get the classiest Air violin case of all. The superior leather-look in four current colors appeals to many people. The matching colored leather handles gives the case a special feature. Light –sturdy – well isolated, the extraordinary features of the Air Technology protect your violin.

GEWA Air Prestige is available as a formed or oblong case. The label „Made in Germany“ not only represents that the GEWA Air Prestige case is made in Germany, but it is also made by our experienced staff in our factory in Adorf/Vogtland.

GEWA Violin case Air Prestige

- **Made in Germany**
- **Especially developed thermoplast shell**
- **Extremely high break resistance**
- **Weight ca. 2.3 kg without accessories**
- **Outstanding isolation characteristics, only 0,025 W/mK thermal conductivity**
- **Hand-sewn leather handle**
- **Lid in leather-look**
- Padded suspension system
- GEWA patented swivel-type bow holder and flexible bow bridge
- Functional, removable accessory pocket
- 2 detachable Neoprene rucksack straps for high wearing comfort
- Combination lock
- Attached music sheet pocket
- Inside black velour padding, protection blanket
- Optional with side handle

GEWA *Air*



316.620	Grey/black
316.630	Red/black
316.650	Cappuccino/black
316.680	Purple/black

316.700 - 316.730

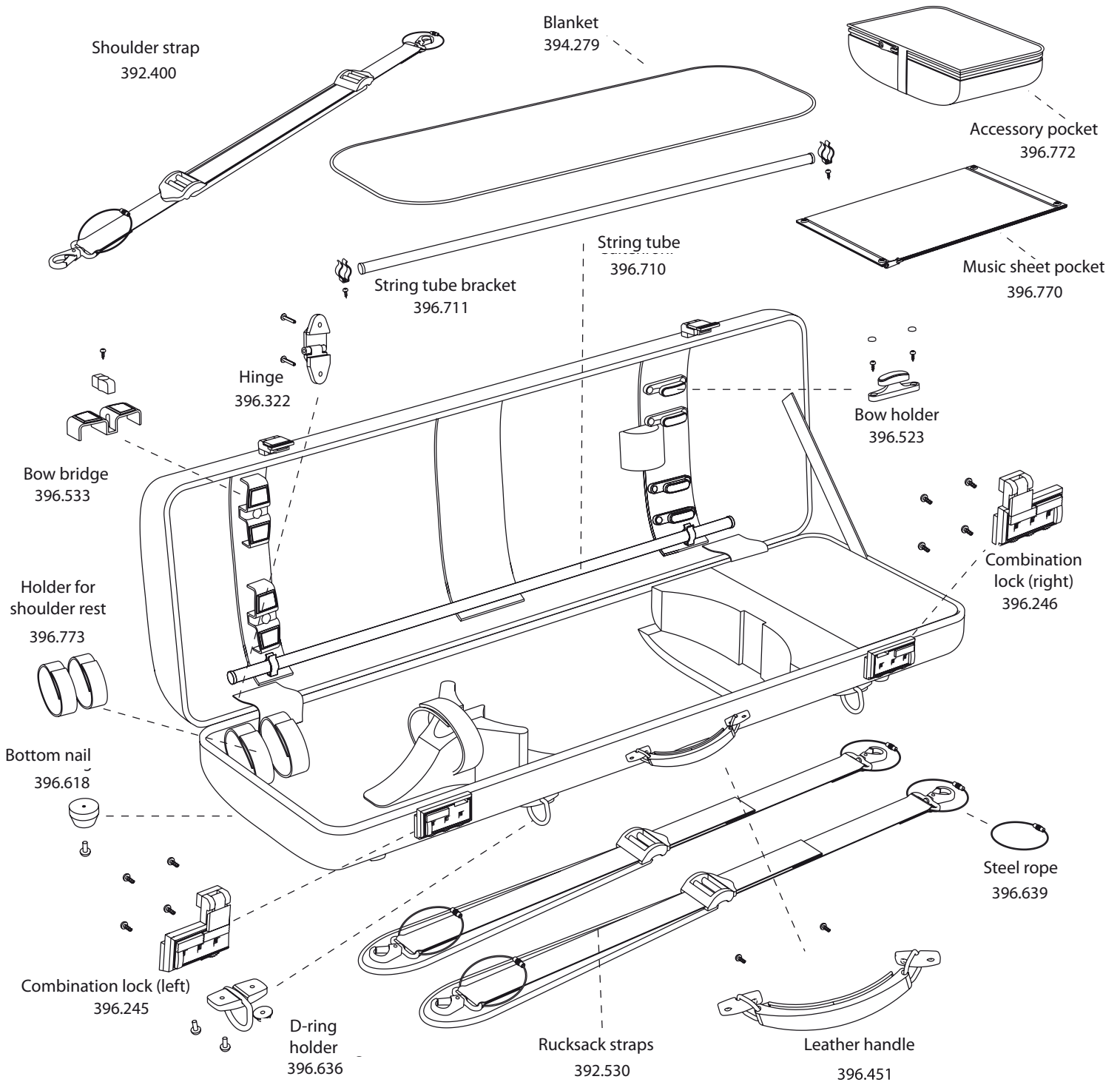

Not all parts included in delivery. Subject to change

GEWA Strings

GEWA Violin case Air Diamond

- **Made in Germany**
- **Especially developed thermoplast-shell**
- **Extremely high break resistance**
- **Weight ca. 2.3 kg without accessories**
- **Outstanding isolation characteristics, only 0,025 W/mK thermal conductivity**
- **Hand-sewed leather handle**
- **Lid in 3-D design**
- Padded suspension system
- GEWA patented swivel-type bow holder and flexible bow bridge
- Functional, detachable accessory pocket
- 2 detachable neoprene rucksack straps for high wearing comfort
- Combination lock, attached music sheet pocket
- Inside black velour padding, protection blanket
- Optional with side handle

GEWA *Air*



316.700	Gold/black
316.710	Black/black
316.720	Silver/black
316.730	Red/black

317.370 – 317.380

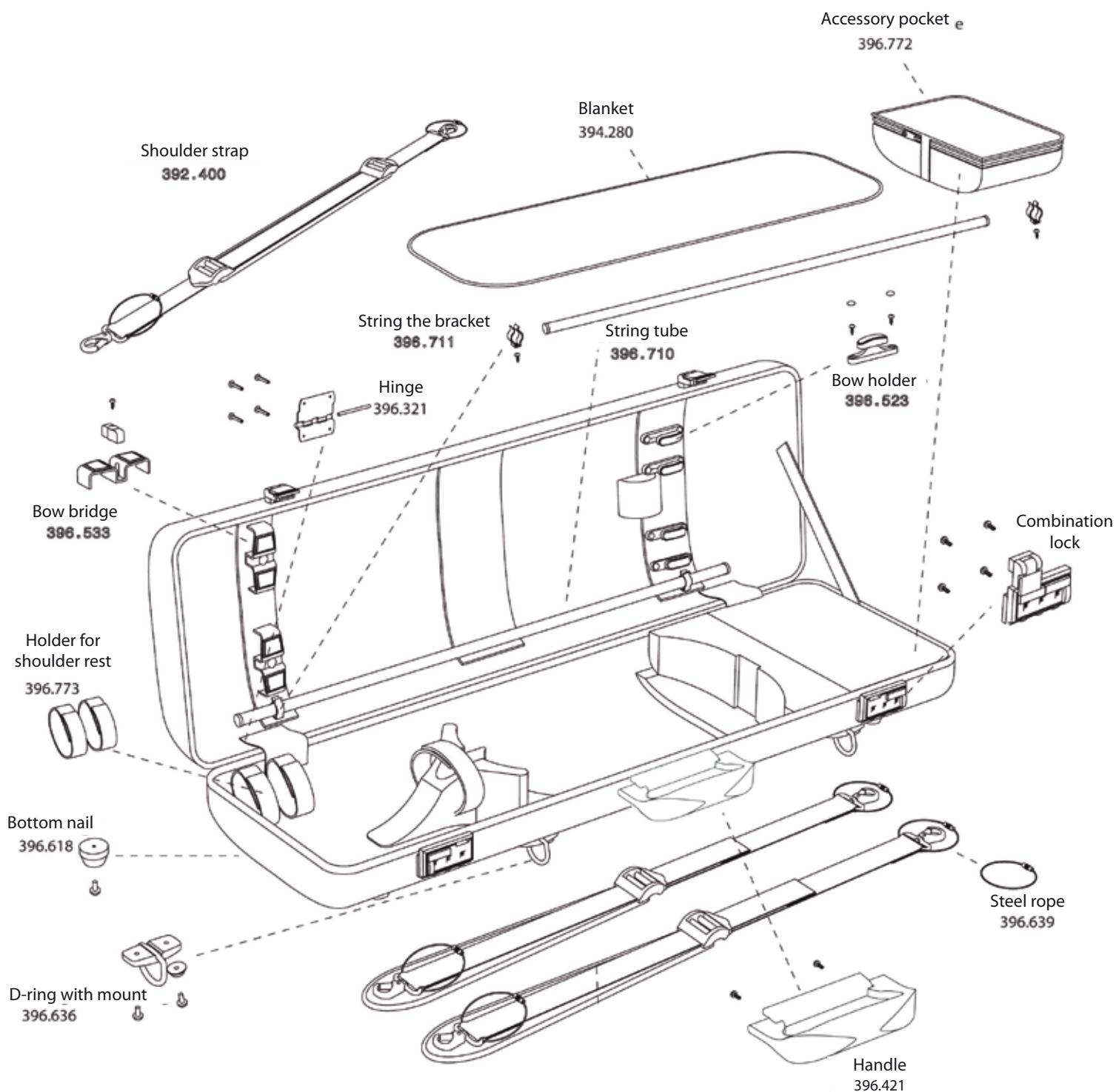

GEWA Strings

The Idea violin case, virtually the bodyguard of the instrument, has rapidly become the favourite of many a musician. A purely functional approach is the formula for success of this case.

Its beautiful shape with high gloss surface testify the taste of the musician, completed by a high-quality and practical interior. Through the 4-point system of the rucksack mounting, the rucksack straps must be worn cross-wise. This results in a higher carrying comfort and a stabilisation of the case while carrying.

Titanium, a Carbon/Fiberglass combination with a breathtaking look, highest protection with German precision combination locks with an extremely low weight.. Elisabeth Pitcaim's and Mira Wang's choice for their invaluable Stradivari instruments.

100% Aramid fibre furnishes the case not only with a unique design, but also offers outstanding protection at an unbelievably low weight. This case stands out and demonstrates the particularity and independence of its owner.

GEWA Violin case Idea 2.0

- Made in Germany
- Shell made of 80 % Hi-Tech carbon fibre fabric
- Weight approx. 2,0 kg
- Padded suspension system
- GEWA swivel type holder, patented
- Flexible bow holder
- Protection blanket
- Accessory pocket
- **2 Neoprene rucksack straps that can be crossed**
- Exterior carbon fibre titanium
- Attached music sheet bag
- Interior velour padding black

GEWA Violin case Idea 1.9

- Made in Germany
- Aramid-Carbon shell
- Weight ca. 1,9 kg
- Padded suspension system
- GEWA swivel type holder, patented
- Flexible bow holder
- Protection blanket
- Accessory pocket
- 2 detachable Neoprene rucksack straps
- Attached music sheet pocket
- Interior velour padding black



317.370



317.375

Carbon, 100 % Carbon fibre offers extreme protection at ultra light weight and the typical, high gloss Carbon look. Because of the 4-point system of the rucksack mounting, the rucksack straps must be worn cross-wise. This results in a higher carrying comfort and a stabilisation of the case while carrying.

GEWA Violin case Idea 1.8

- Made in Germany
- Carbon shell made of 100% carbon fibre
- Ultra-light ca. 1,8 kg
- Padded suspension system
- GEWA swivel-type holder patented
- Flexible bow holder
- Protection blanket
- Accessory pocket
- **2 Neoprene rucksack straps to be worn crosswise**
- Exterior carbon fibre black
- Attached music sheet pocket
- Interior velour padding black

1,8 kg



317.380

GEWA Strings

GEWA Violin double case Liuteria Concerto

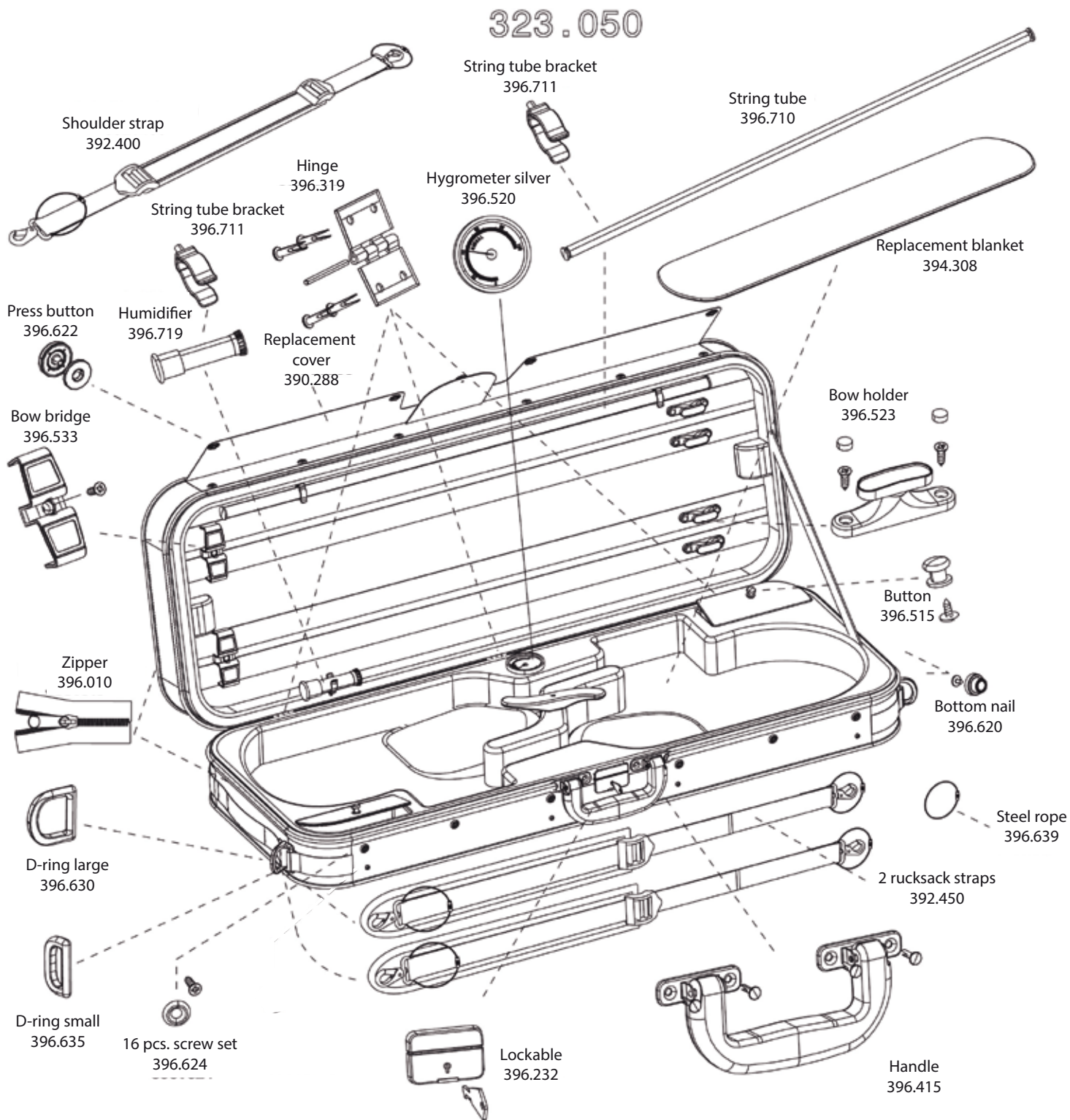

Not all parts included in delivery. Subject to change

GEWA Strings

The Concerto series – thermal shell, equipped with everything that is necessary, quality GEWA components with a screw-attached, robust cover.

GEWA Violin double case Liuteria Concerto

- For 2 violins
- Thermo shell
- Padded suspension system
- Weight approx. 3,4 kg
- Screw attached cover with music sheet pocket, water repellent
- GEWA swivel type holder patented
- flexible bow holder
- Blanket
- Accessory compartments
- 2 Detachable Neoprene rucksack straps
- Exterior Tex black
- Interior velour blue



323.050* 4/4

323.130 – 323.180

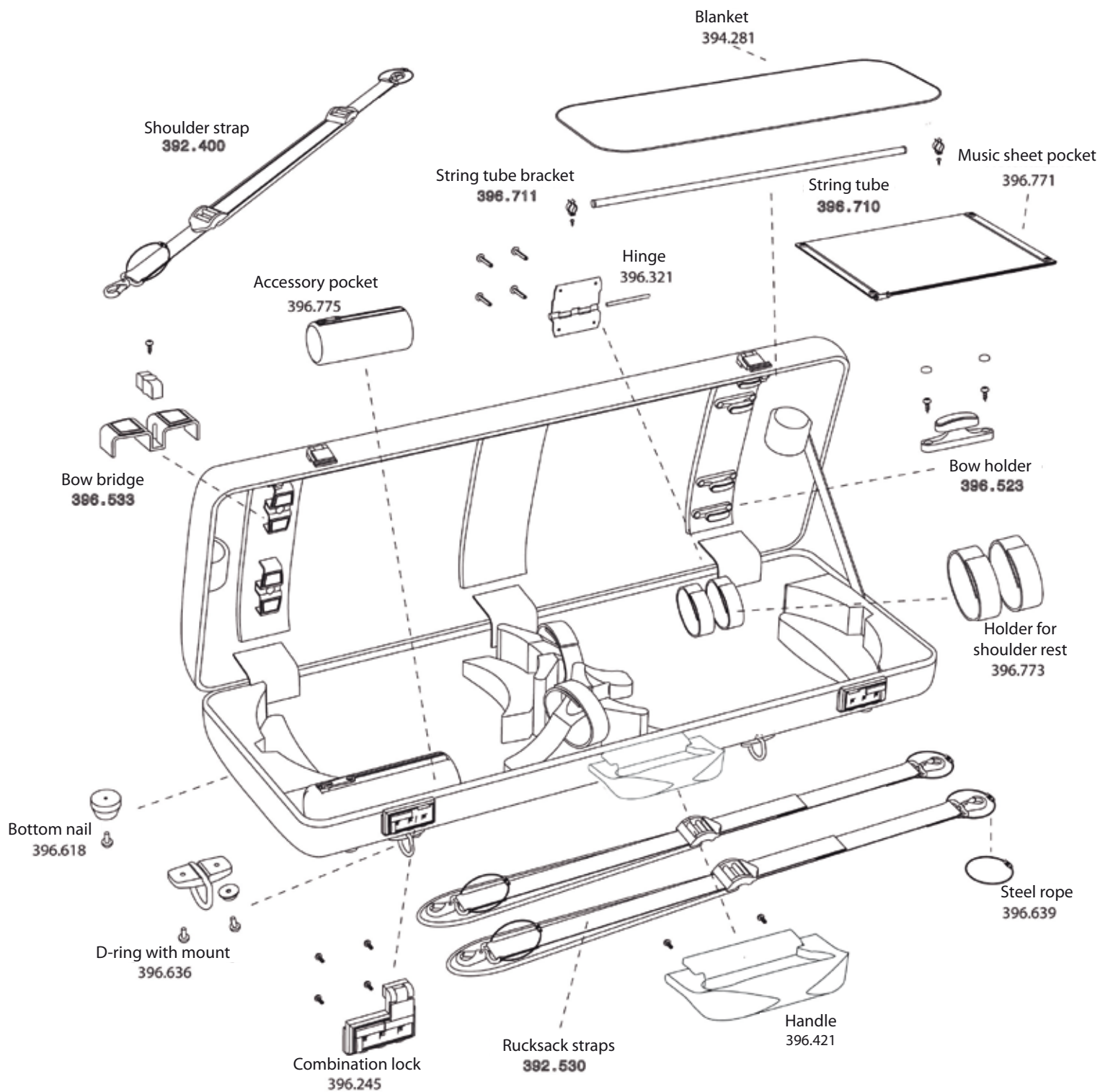

GEWA Strings

The Idea violin case, virtually the bodyguard of the instrument, has rapidly become the favourite of many a musician.

A purely functional approach is the formula for success of this case. Its beautiful shape with high gloss surface testify the taste of the musician, completed by a high-quality and practical interior. Through the 4-point system of the rucksack mounting, the rucksack straps must be worn cross-wise.

This results in a higher carrying comfort and a stabilisation of the case while carrying.

GEWA Violin double case Idea 3.3

- For 2 violins
- **Made in Germany**
- **Fibre glass reinforced synthetic resin shell**
- **Weight ca. 3,5 kg**
- Padded suspension system
- GEWA swivel type holder patented
- Flexible bow holder
- Protection blanket
- Accessory pocket
- 2 detachable Neoprene rucksack straps
- Attached music sheet pocket
- Interior velour padding black



323.130	Red
323.140	White

Carbon – 100 % carbon fibre, extreme protection at ultra light weight and typical, high gloss carbon look.

Through the 4-point system of the rucksack mounting, the rucksack straps must be worn cross-wise.

This results in a higher carrying comfort and a stabilisation of the case while carrying.

GEWA Violin double case Idea 2.5

- For 2 violins
- **Made in Germany**
- **Shell made of Hi-Tech carbon fibre fabric**
- **Ultra light, ca. 2,6 kg**
- Padded suspension system
- GEWA swivel type holder patented
- Flexible bow holder
- Blanket
- Accessory pocket
- 2 detachable Neoprene rucksack straps
- Attached music sheet pocket
- Exterior carbon fibre black
- Interior velour padding black



323.180

323.600

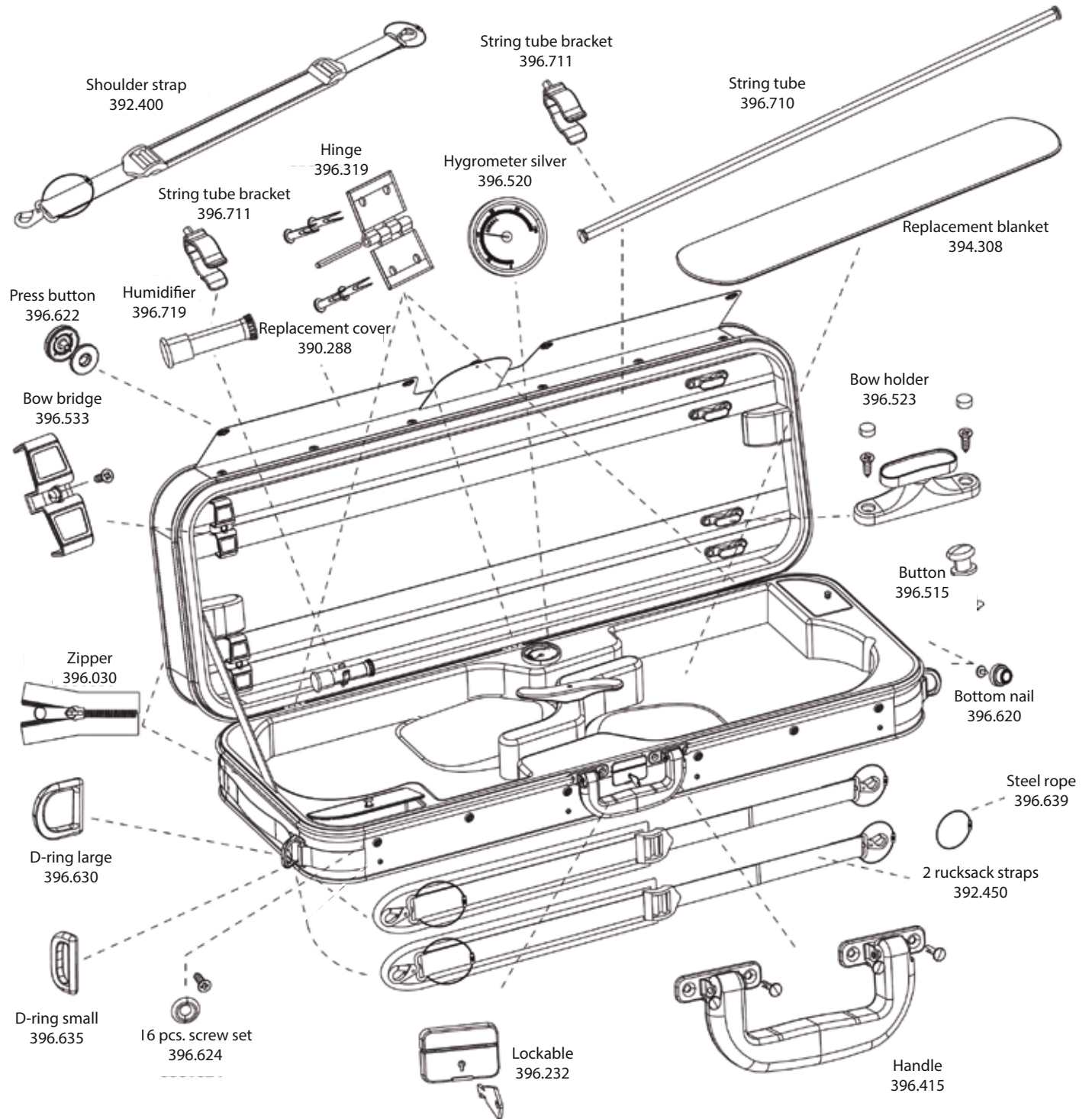

GEWA Strings

The Maestro series- the next step for serious musicians and students.
Thermal shell on the basis of the legendary JAEGER shape.
High-quality materials and components, e.g. Swiss lock. Medium weight.

GEWA Double case for 1 viola and 1 violin **Liuteria Maestro**

- Wooden shell
- Screw-attached cover with music sheet pocket, water-repellent
- Padded suspension system
- Weight approx. 4,8 kg
- Adjustable interior 36,0-42,5 cm
- Flexible bow holder, GEWA swivel type bow holder
- Swiss lock
- 2 detachable rucksack straps
- Exterior Tex black
- Interior velvet plush blue



323.600*

328.213 - 328.216

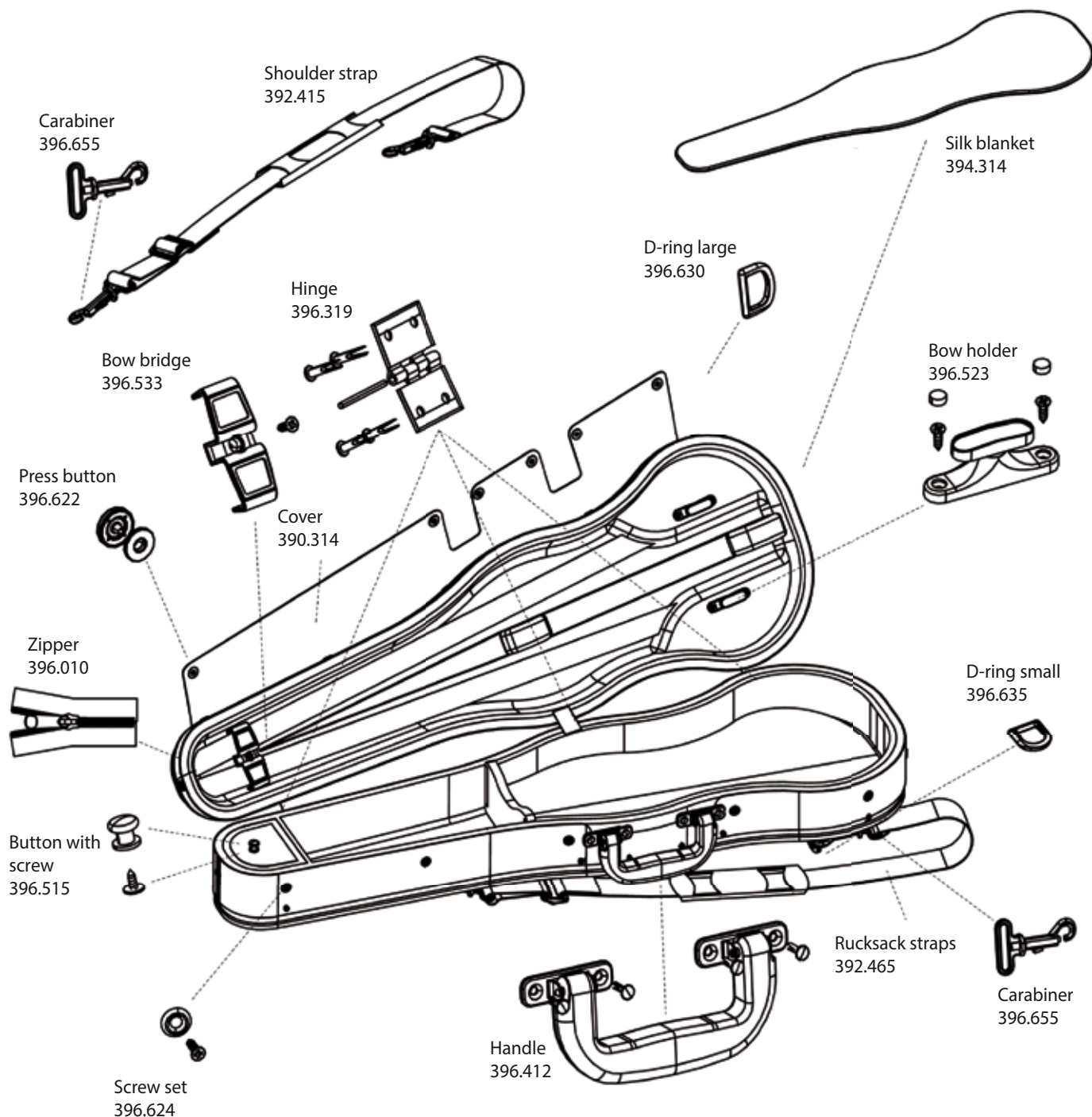

Not all parts included in delivery. Subject to change

GEWA Strings

The Concerto series- thermal shell, equipped with everything that is necessary, Quality GEWA components with screw-attached, robust cover. Medium weight.

GEWA Form shaped viola case Liuteria Concerto

- Thermal shell
- Padded suspension system
- Weight approx. 2,0 kg
- Screw-attached cover, water-repellent
- GEWA swivel type holder patented
- Flexible bow holder
- Protection blanket
- Accessory compartment
- 2 detachable rucksack straps
- Exterior Tex black
- Interior velour blue



328.213*	III 38 cm
328.214*	IV 39,5 cm
328.215*	V 41,5 cm
328.216*	VI 43 cm

Measurements for GEWA Form shaped viola case Liuteria Concerto

Instrument measurements

Case size	Upper width	Lower width	Body length
III	18	22	38
IV	19	24	39,5
V	19,5	24,5	41,5
VI	20,5	25	43,0

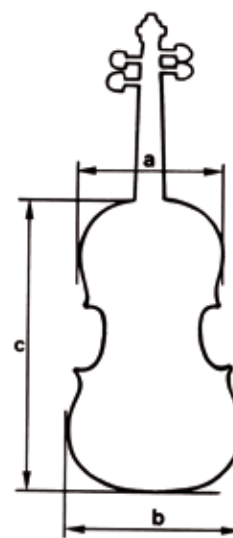

329.213 - 329.216

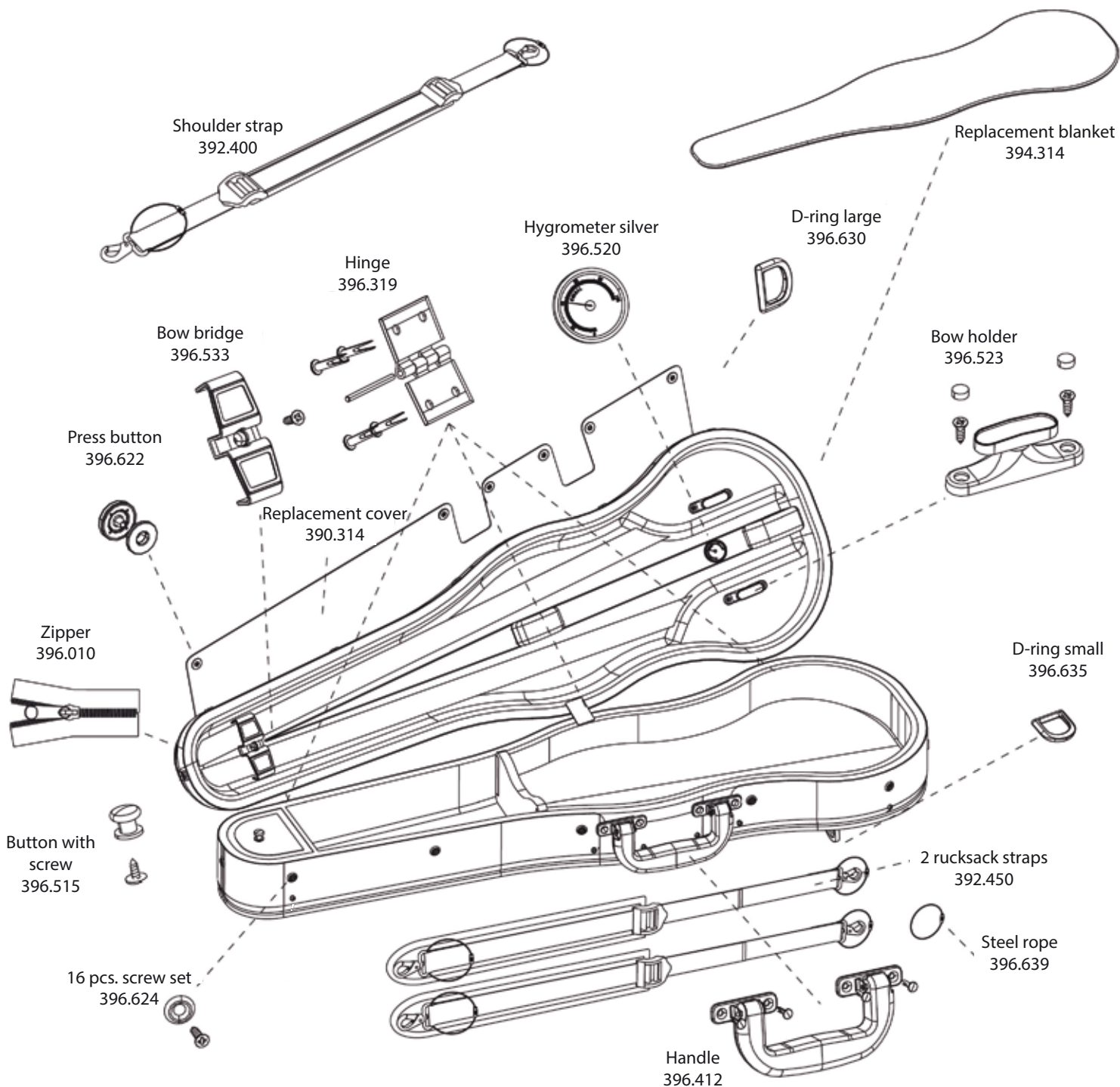

Not all parts included in delivery. Subject to change

GEWA Strings

The Maestro series - the next step for dedicated musicians and students. Thermo shell based on the legendary JAEGER shape. High-quality materials and components, e.g. Swiss lock. Medium weight.

GEWA Form shaped viola case Liuteria Maestro

- Thermo shell
- Padded suspension system
- **Weight approx. 2,1 kg**
- screw attached cover, water repellend
- GEWA GEWA patented swivel type bow holders, flexible bow holder, Protection blanket
- Swiss lock
- 2 detachable Neoprene rucksack straps
- Leather handle, accessory compartment
- Exterior Tex black
- Interior plush blue



329.213*	III 38 cm
329.214*	IV 39,5 cm
329.215*	V 41,5 cm
329.216*	VI 43 cm

Measurements for GEWA Form shaped viola case Liuteria Maestro

Instrument measurements

Case size	Upper width	Lower width	Body length
III	18	22	38
IV	19	24	39,5
V	19,5	24,5	41,5
VI	20,5	25	43,0

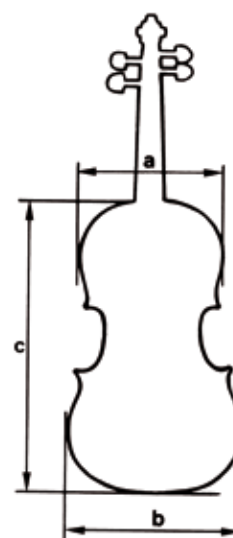

331.020 - 331.025

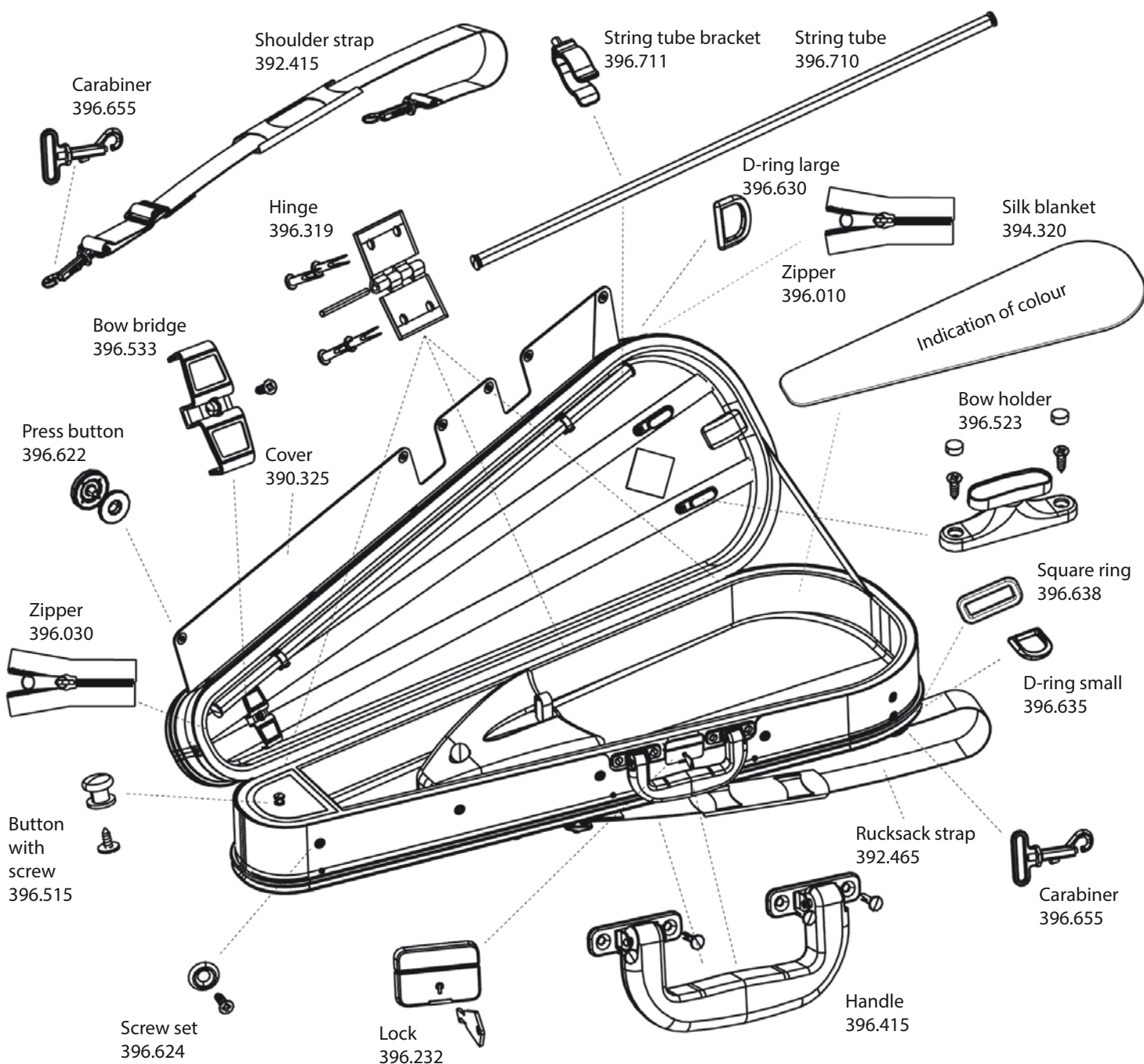

GEWA Strings

The **GEWA Varianta** calls attention because of its special shape. This case distinguishes itself by simple adjustability and high-quality materials and components, e.g. Swiss lock. Medium weight.

GEWA Viola case Liuteria Varianta

- **Thermo shell**
 - Padded suspension system
 - Weight approx. 3,4 kg
 - **Screw-attached cover with music sheet pocket, water-repellant**
 - GEWA swivel-type holder patented, flexible bow holder
 - Swiss lock
 - Protection blanket
 - Accessory compartment
 - **Adjustable interior 38-42,5 cm**
 - Lower body width up to 25,8 cm
 - 2 detachable rucksack straps
-
- Exterior Tex black
 - Interior velour red



331.020*

- Exterior Tex black
- Interior velour blue



331.025*

GEWA Strings

GEWA Viola case Liuteria Concerto

332.300

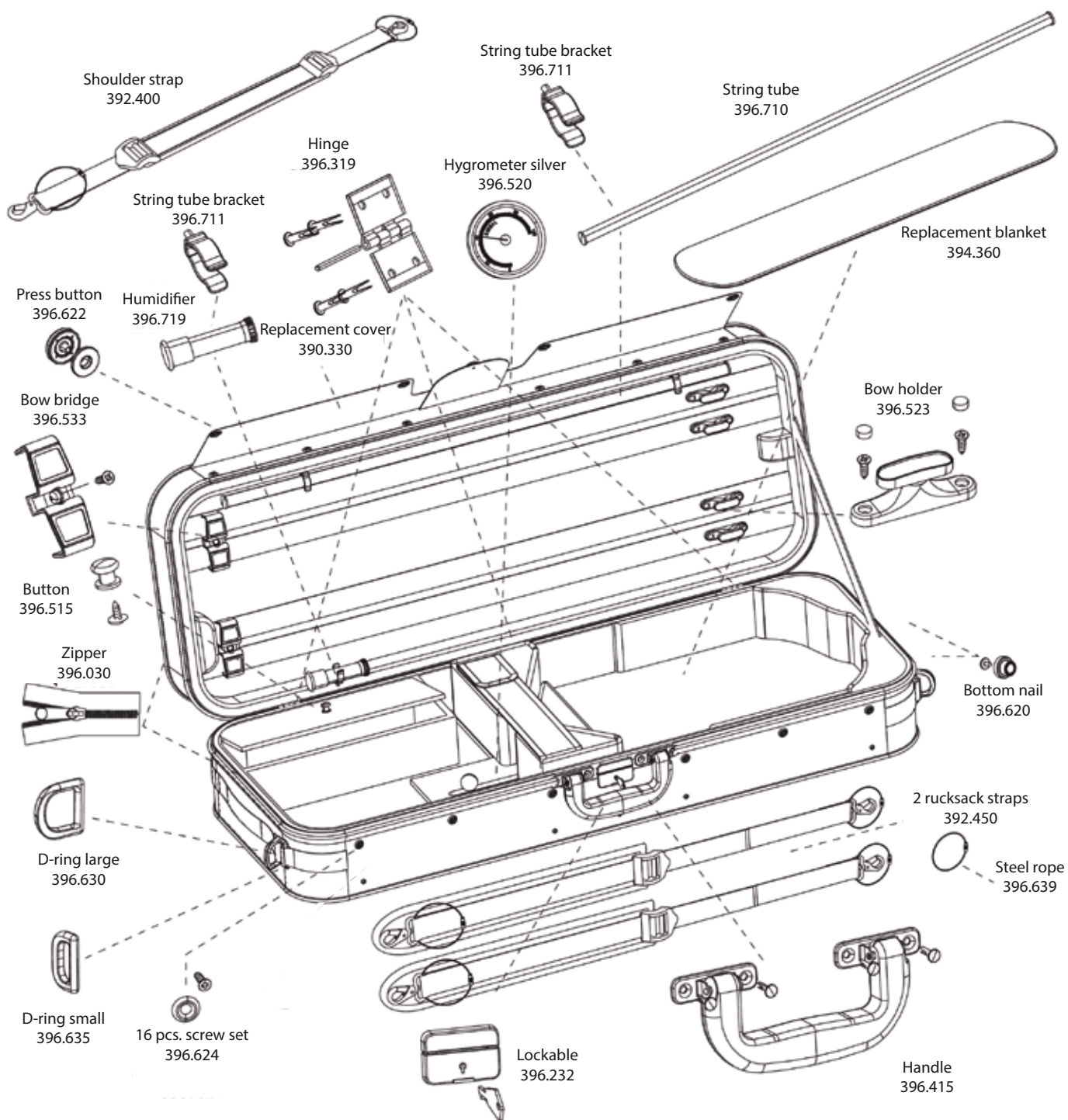

Not all parts included in delivery. Subject to change

GEWA Strings

The Concerto series- the ideal, well-priced case for students and beginners. Thermal shell, equipped with everything that is necessary, Quality GEWA components with screwed, robust cover. Medium weight.

GEWA Viola case Liuteria Concerto

- Thermo shell
- Padded suspension system
- Weight approx. 3,6 kg.
- **Screw-attached cover with music sheet pocket, water repellant**
- GEWA swivel-type holder patented, flexible bow holder
- Swiss lock
- Protection blanket
- Accessory compartment
- **Adjustable interior 36,0-42,5 cm**
- Lower body width up to 26,5 cm
- 2 detachable Neoprene rucksack straps
- Exterior Tex black
- Interior velour blue



332.300*

334.560 – 334.684

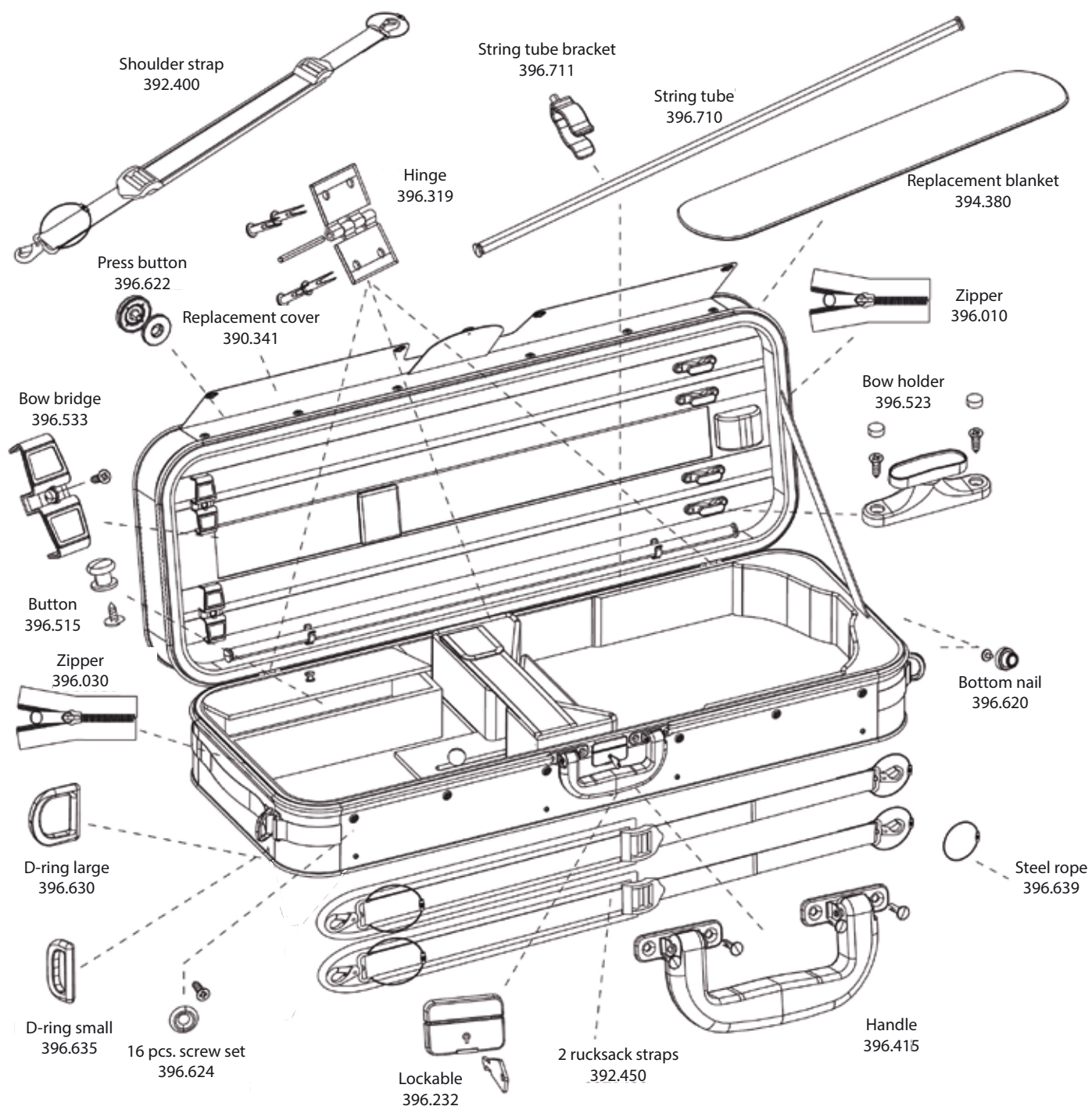

Not all parts included in delivery. Subject to change

GEWA Strings

The Strato series – the workhorse amongst the GEWA cases.

This is the case for the orchestra musician, the instructor, the teacher who wants his instrument protected by all means and who travels a lot. Very low weight, robust, functional.. Polyfoam shell with a wooden frame, very light, exchangeable cover, rucksack set and high-quality, resilient materials.

The Strato De Luxe series – If orchestra musicians, instructors and teachers place more emphasis on the interior padding, they opt for the more high-grade model of the Strato case. The specially selected velvet plush makes the case classy. It is still light, professionally equipped with GEWA quality components and a robust, screw-attached cover with sheet music pocket. Low weight.

GEWA Viola case Strato Super Light Weight

- Made in Germany
- High-density polyfoam shell
- Padded suspension system
- Ultra light approx. 2,5 kg
- Teflon-coated cover with large music sheet pocket
- GEWA swivel type holder patented
- Flexible bow holder
- Swiss lock
- Protection blanket
- Accessory compartment
- Adjustable interior
- Body length from 36 - 42,5 cm
- Lower body width up to 25 cm
- 2 detachable Neoprene rucksack straps

- Exterior Conatex black
- Interior velour dark blue



334.560

- Exterior Conatex dark blue
- Inside velour anthracite



334.562

- Exterior Conatex dark brown
- Interior velour beige



334.564

GEWA Viola case Strato De Luxe

- Teflon-coated screw-attached cover with large music sheet pocket
- Adjustable interior
- Made in Germany
- High density polyfoam shell
- Padded suspension system
- Ultra light ca 2.6 kg
- GEWA swivel-type bow holder pat., Flexible bow bridge
- Swiss lock
- Protection blanket
- Accessory compartment
- Fits body length 36-42,5 cm
- Lower width 25 cm
- 2 detachable Neoprene rucksack straps

- Exterior Conatex black
- Interior velvet plush burgundy



334.680

- Exterior Conatex black
- Interior velvet plush dark blue



334.682

- Exterior Conatex dark blue
- Interior velvet plush silver



334.684

335.230 – 335.380

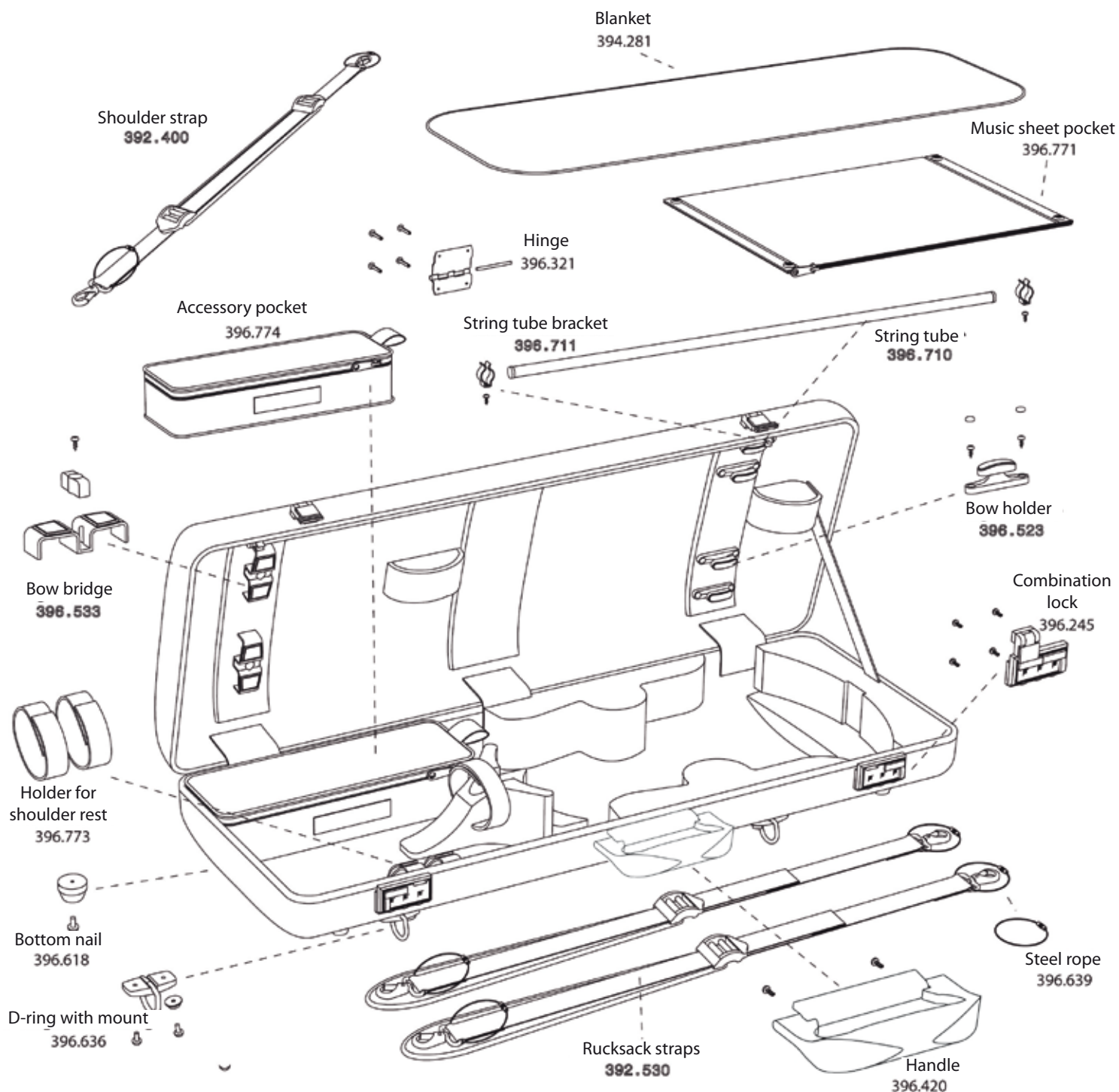

GEWA Strings

Titanium, a Carbon/Fiberglass combination with a breathtaking look and highest protection with German precision combination locks at an extremely low weight. Because of the 4-point system of the rucksack mounting, the rucksack straps must be worn cross-wise. This results in a higher carrying comfort and stabilisation of the case while carrying.

GEWA Viola case Idea 2.8

- **Made in Germany**
- **Carbon shell made of 80% carbon fibre fabric**
- **Weight approx. 2,9 kg**
- Padded suspension system
- GEWA swivel type holder patented
- Flexible bow holder
- Protection blanket, accessory pocket
- Attached music sheet pocket
- 2 detachable Neoprene rucksack straps
- Exterior carbon fibre titanium
- Interior velour padding black



335.370

Carbon, 100 % Carbon fibre offers extreme protection at ultra light weight and the typical, high gloss Carbon look. Because of the 4-point system of the rucksack mounting, the rucksack straps must be worn cross-wise. This results in a higher carrying comfort and a stabilisation of the case while carrying.

GEWA Viola case Idea 2.6

- **Made in Germany**
- **Carbon shell made of 100% carbon fibre fabric**
- **Weight ca. 2,8 kg**
- Padded suspension system
- GEWA swivel type holder patented
- Flexible bow holder
- Protection blanket, accessory pocket
- Attached music sheet pocket
- 2 detachable Neoprene rucksack straps
- Exterior carbon fibre black
- Interior velour padding black



335.380

337.100 – 337.110

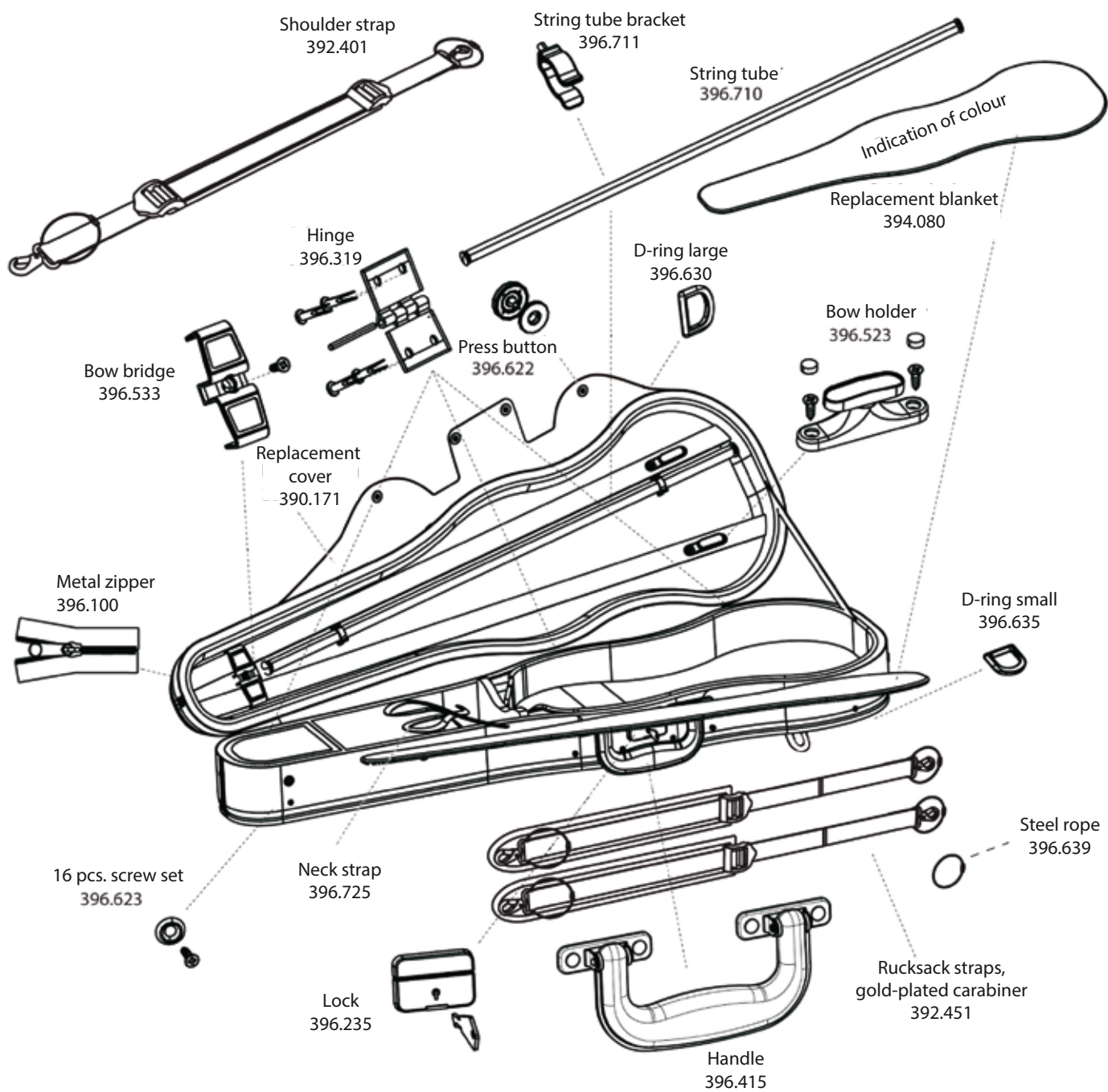

GEWA Strings

The JAEGER series - the legend per se.

The reputation of GEWA is based on this case. Quality since 1925, no compromises since 1925. The best is just good enough for the JAEGER case. Exclusively the most experienced master craftsmen manufacture this virtually indestructible gem in Adorf. Carefully selected leather and cloth for the interior and highly resilient precision fittings are made with close attention to detail. From time to time we merely need to exchange a worn cover after 30 years. Musicians recognize at once that a serious colleague is entering the room when they transport their instrument in a "JAEGER". Countless travel anecdotes are centered around this case. Frank-Peter Zimmermann's and many others' preferred companion on concert tours.

GEWA Form shaped violin cases JAEGER Prestige

- **Made in Germany**
- De Luxe violin case
- **Thermo shell**
- Padded suspension system
- Weight approx. 2,0 kg
- Screw-attached cover, water-repellent
- GEWA swivel type holder patented
- Flexible bow holder
- Swiss lock
- Protection blanket
- Accessory compartment
- Leather handle
- 2 padded Neoprene rucksack straps
- Interior velvet plush green

JAEGER



337.100 4/4 Outside brown
337.110 4/4 Outside black with carbon optic

337.200 – 337.210

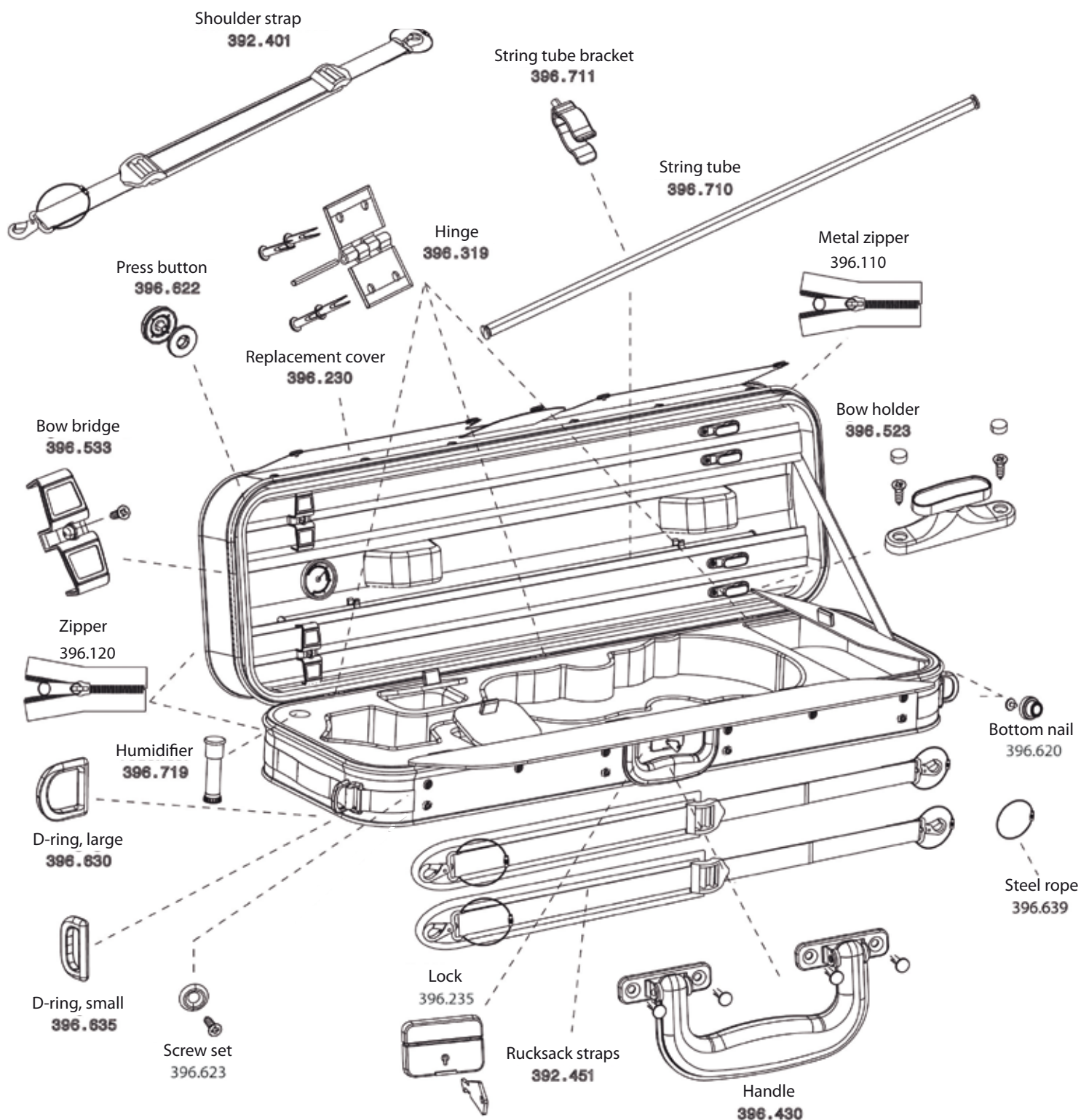

GEWA Strings

GEWA Violin case JAEGER Prestige

- **Made in Germany**
- De Luxe violin oblong case
- **Thermo shell**
- Padded suspension system
- Weight approx. 3,1 kg
- Screw attached cover with large music pocket, water repellent
- GEWA swivel type holder patented
- flexible bow holder
- Blanket
- Accessory compartments
- Leather handle
- 2 Detachable Neoprene rucksack straps
- Silk blanket
- Interior velvet plush green

JAEGER



337.200 Exterior brown
337.210 Outside black with carbon optic

GEWA Strings

GEWA Violin case JAEGER Prestige

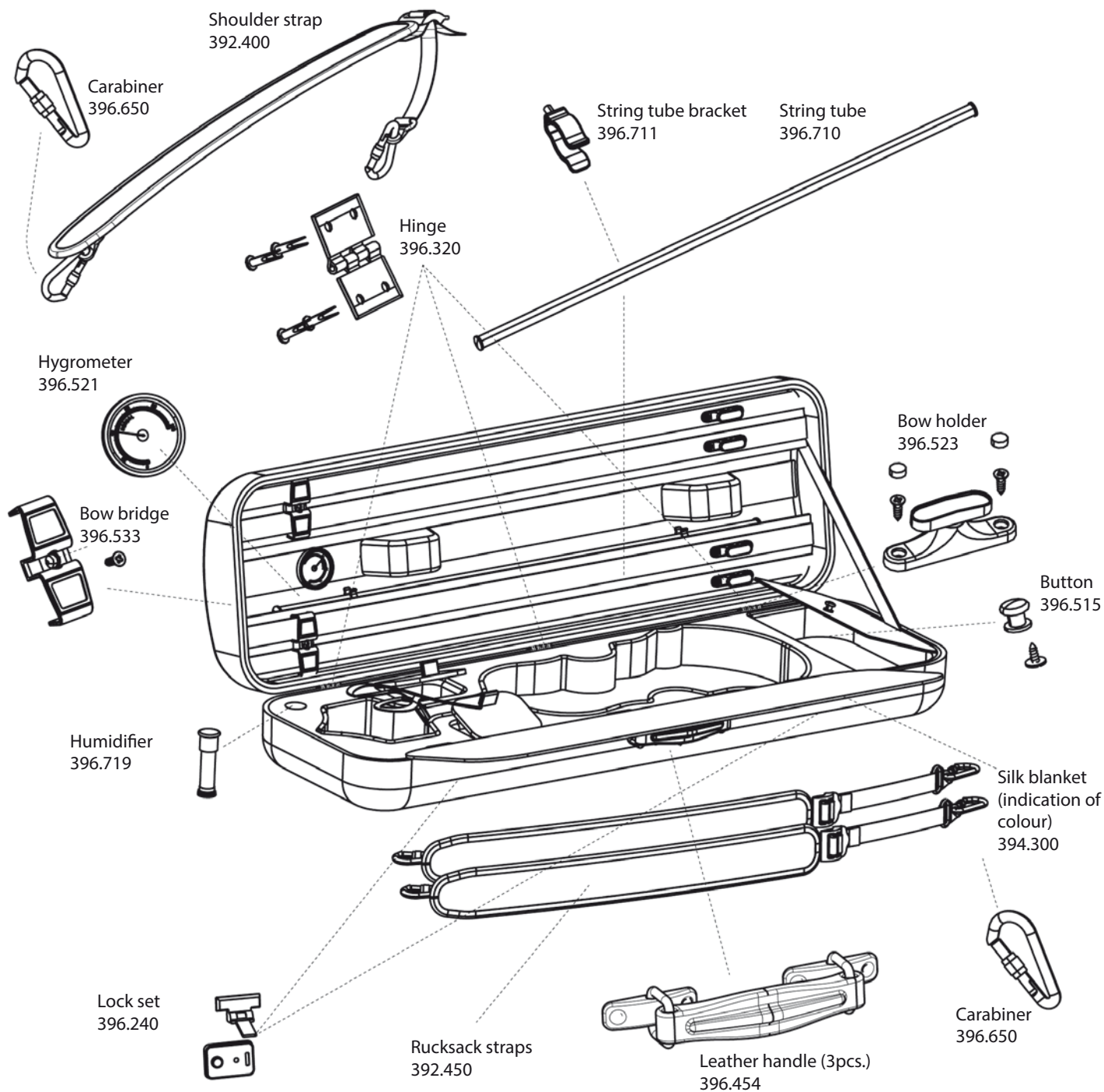

Not all parts included in delivery. Subject to change

GEWA Strings

If you want the JAEGER case to have a special look, you choose the model with the leather cover that was put on by hand.

GEWA Violin case JAEGER Prestige

- **Made in Germany**
 - De Luxe leather violin case
 - **Thermo shell**
 - Padded suspension system
 - Weight approx. 2,9 kg
 - Leather cover, placed by hand
 - GEWA swivel type holder patented
 - Flexible bow holder
 - Swiss lock
 - Protection blanket
 - Accessory compartments
 - Hand-sewn leather handle
 - Genuine leather carrying strap
-
- Exterior black calf leather
 - Interior velvet plush burgundy



337.300 4/4

- Exterior calf leather mocca
- Interior velvet plush green



337.301 4/4

- Exterior calf leather burgundy
- Interior velvet plush silver grey



337.302 4/4

GEWA Strings

GEWA Violin double case JAEGER Prestige

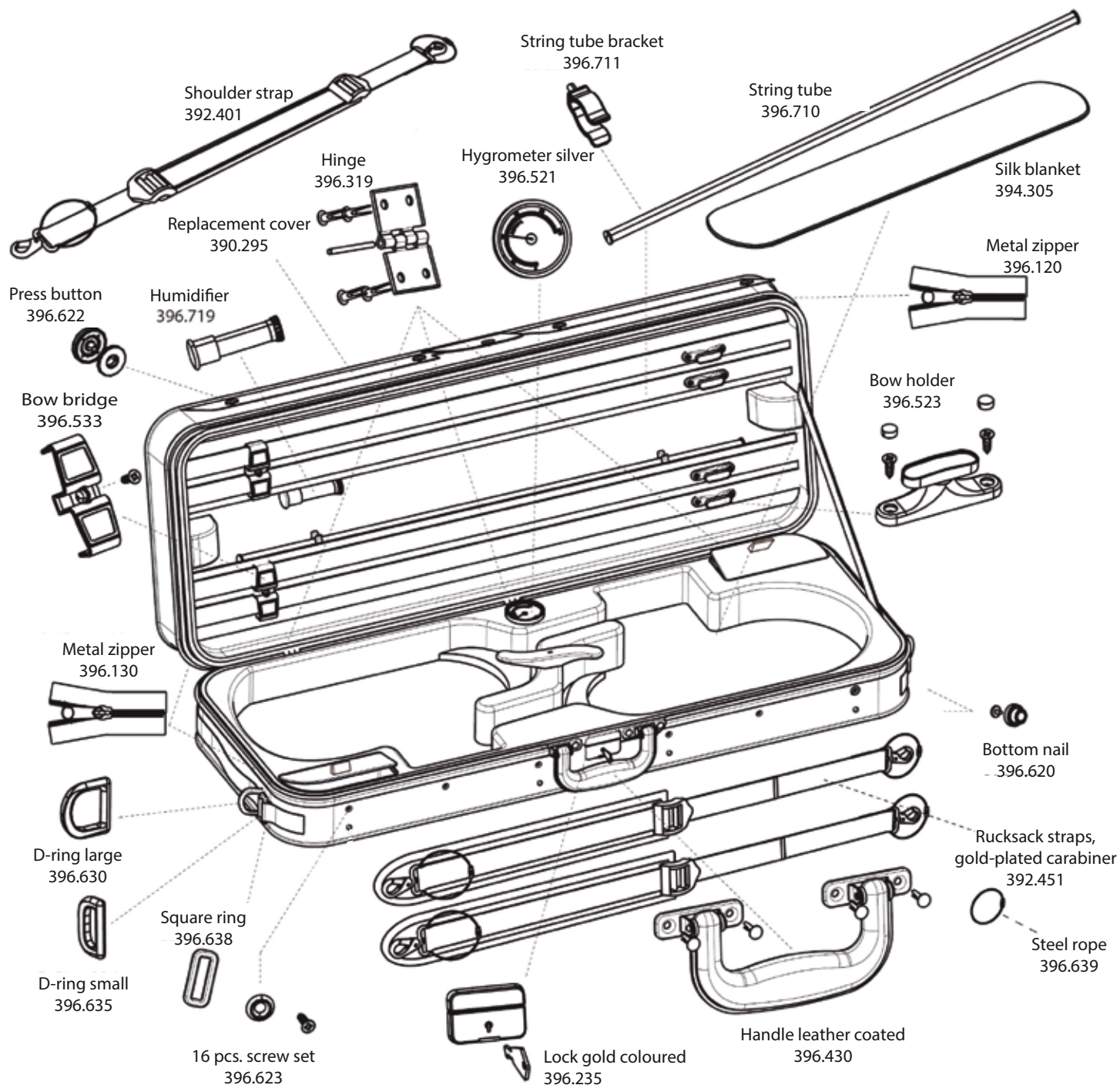

Not all parts included in delivery. Subject to change

GEWA Strings

GEWA Violin double case JAEGER Prestige

- For 2 violins
- **Made in Germany**
- De Luxe double case
- **Thermo shell**
- Padded suspension system
- Weight approx. 3,8 kg
- Screw-attached cover with large music pocket, water-repellent
- GEWA swivel-type holder patented
- Blanket
- Leather handle
- 2 detachable Neoprene rucksack straps
- Interior velvet plush green

JAEGER



337.500 Exterior brown
337.510 Outside black with carbon optic

GEWA Strings

GEWA Viola case JAEGER Prestige

337.700

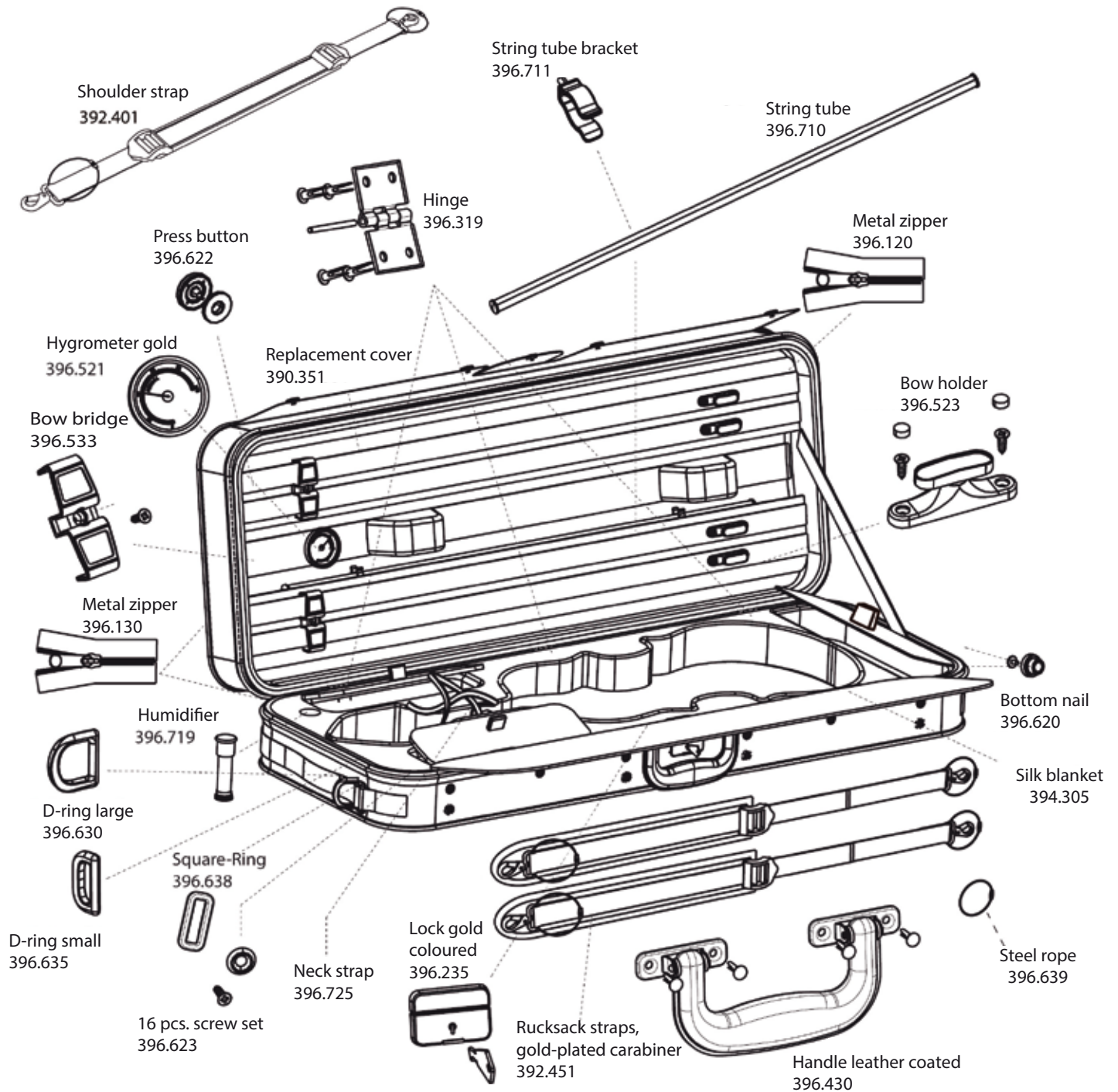

Not all parts included in delivery. Subject to change

GEWA Strings

GEWA Viola case JAEGER Prestige

- **Made in Germany**
- De Luxe viola oblong case
- **Thermo shell**
- Padded suspension system
- Weight approx. 3,8 kg
- Screw-attached cover with large music pocket, water-repellent
- GEWA swivel-type holder patented
- flexible bow holder
- Blanket
- Accessory compartments
- Leather handle
- 2 detachable Neoprene rucksack straps
- Paper drawing scale 1 : 1 necessary
- Handmade JAEGER interior
- On customer request **outside Soft Tex**
- Interior velvet plush on customer request

JAEGER



341.210 – 341.280

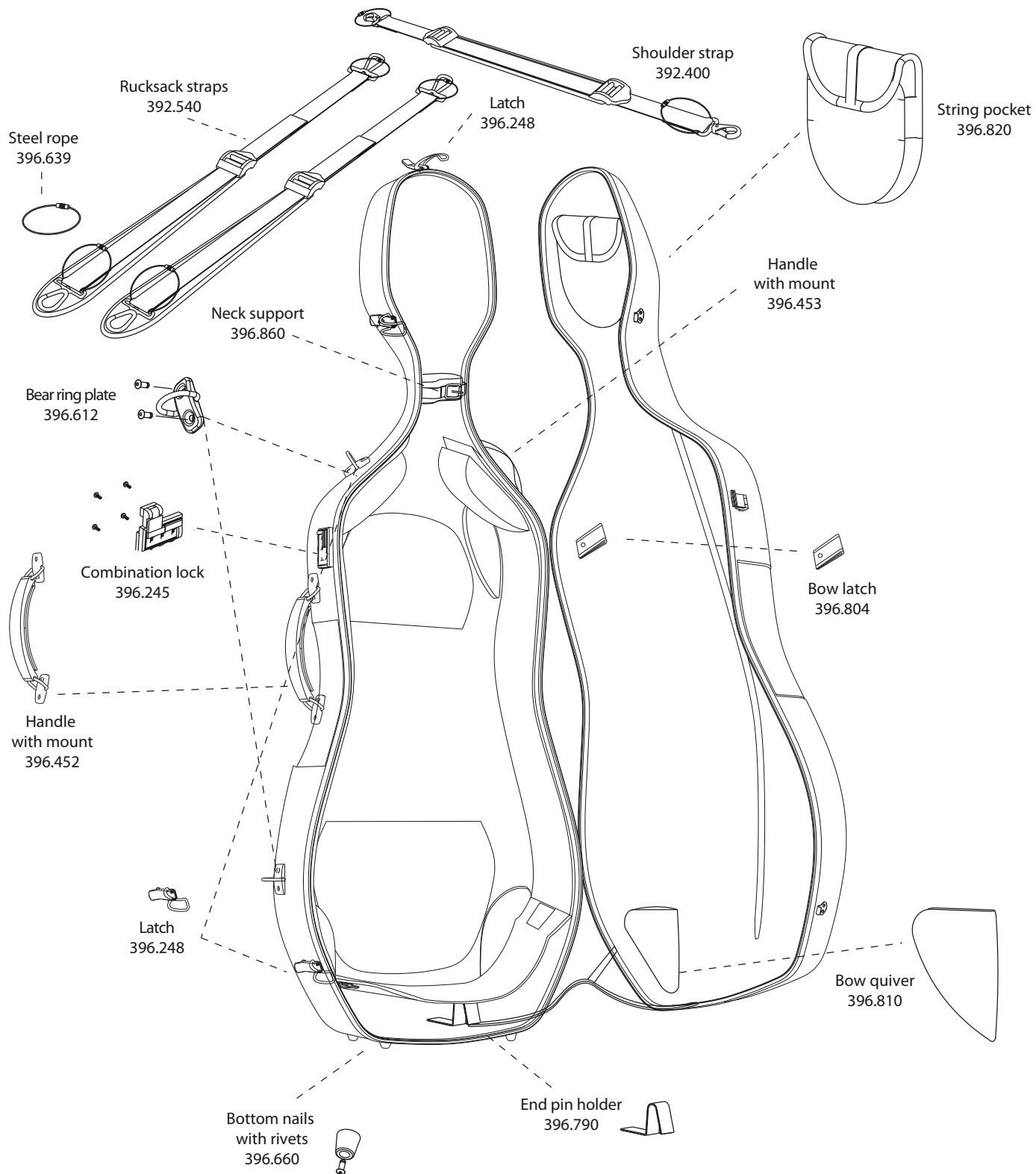

Not all parts included in delivery. Subject to change

GEWA Strings

The Air series – the ideal case for cellists who travel a lot. The Air Cello case is innovative, light and sporty, yet elegant. It has an excellent impact absorption and is easy to transport thanks to its optimised outer dimensions. The exposed places are protected by a narrow but effective aluminium edge. The ergonomically designed back section allows for fatigue-proof carrying when using the supplied rucksack straps. The GEWA Air Cello case – perfect for students and professionals.

GEWA Cello case Air

- Made in Germany
- Weight approx. 3.9 kg
- Specially developed Thermoplast shell
- Extremely high break-resistance
- Outstanding isolation characteristics, only 0,025 W/mK thermal conductivity
- Padded, custom-fit suspension system
- Combination lock, 3 GEWA special locks
- Bridge protection thanks to aluminium bar
- 2 neoprene rucksack straps with security strap
- Hand-made genuine leather handles
- Interior: velvet plush



reddot award 2016
winner



GEWA Cello case Air inner measurements in cm

Total length	Body upper width	Body lower width	Total height incl. bridge
130	36	47	29

3,9 kg



341.210	Black/black	341.245	White/bordeaux
341.215	Black/burgundy	341.250	Beige/black
341.220	Grey/black	341.260	Orange/black
341.230	Red/black	341.270	Brown/black
341.240	white/black	341.280	Purple/black
341.244	White/blue	341.290	Blue/black

342.115 – 342.150

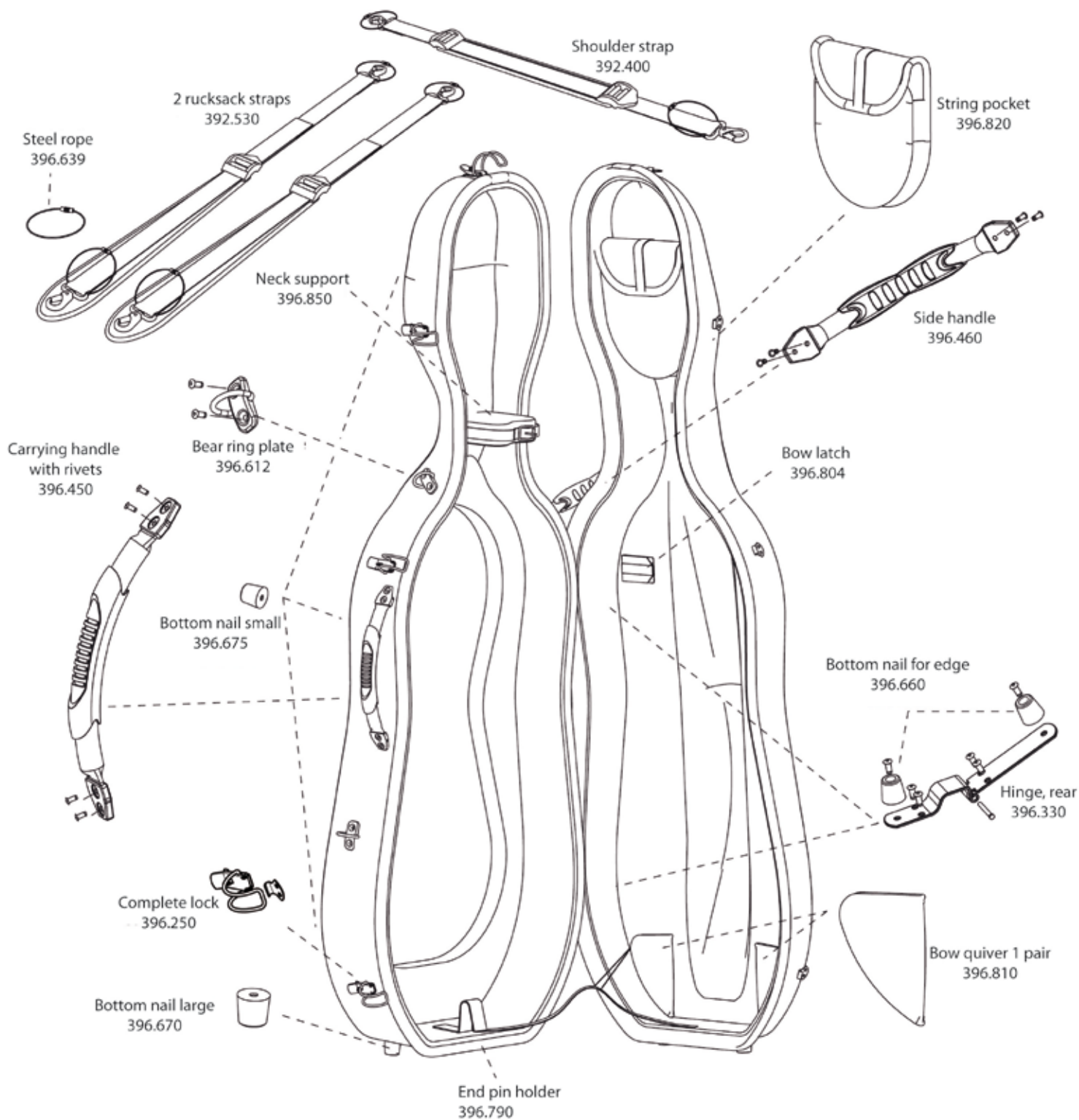

GEWA Strings

Fiberglass – the entry into the Idea world, well-priced protection with a moderate weight. Fiberglass mats are impregnated with resin and moulded, using our own process. High torsion resistance, low weight, medium insulation qualities, excellent impact absorption.

GEWA Cello case Idea Futura

- Made in Germany
- Fibre glass reinforced synthetic resin shell
- Weight approx. 4,8 kg
- Padded suspension system
- SPS-lock-system
- 4 GEWA special locks
- Accessory pocket
- 2 detachable Neoprene rucksack straps
- Velour padding

4,8 kg

GEWA Cello case Idea Futura inner measurements in cm

Total length	Body upper width	Body lower width	Total height incl. bridge
129	36	45	28



342.115 Black/red
342.120 Anthracite/red
342.125 Dark blue/blue

342.130 crimson/anthracite
342.135 White/red
342.150 Dark green/anthracite

342.180 – 342.183

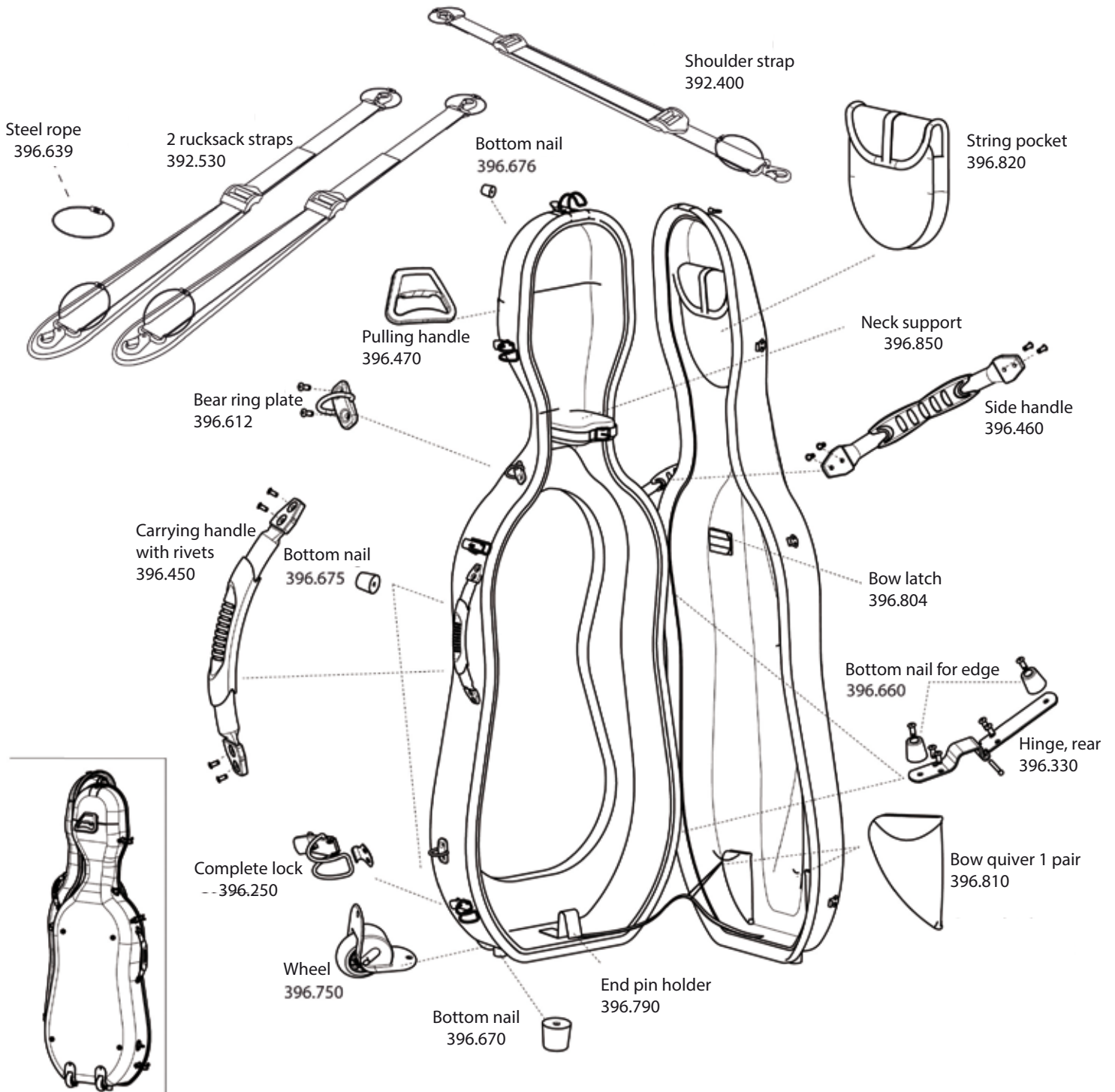

GEWA Strings

Fiberglass – the entry into the Idea world, well-priced protection with a moderate weight. Fiberglass mats are impregnated with resin and moulded, using our own process. High torsion resistance, low weight, medium insulation qualities, excellent impact absorption.

GEWA Cello case Idea Futura Rolly

- **Made in Germany**
- Fibre glass reinforced synthetic resin shell
- **Weight ca. 4,9 kg**
- Padded suspension system
- **SPS-lock-system**
- 4 GEWA special locks
- 2 integrated rubber wheels
- Accessory pocket
- 2 detachable Neoprene rucksack straps
- Velour padding



4,9 kg

GEWA Cello case Idea Futura Rolly inner measurements in cm

Total length	Body upper width	Body lower width	Total height incl. bridge
129	36	45	28

342.180	black/burgundy
342.181	night blue / blue

342.210 – 342.245

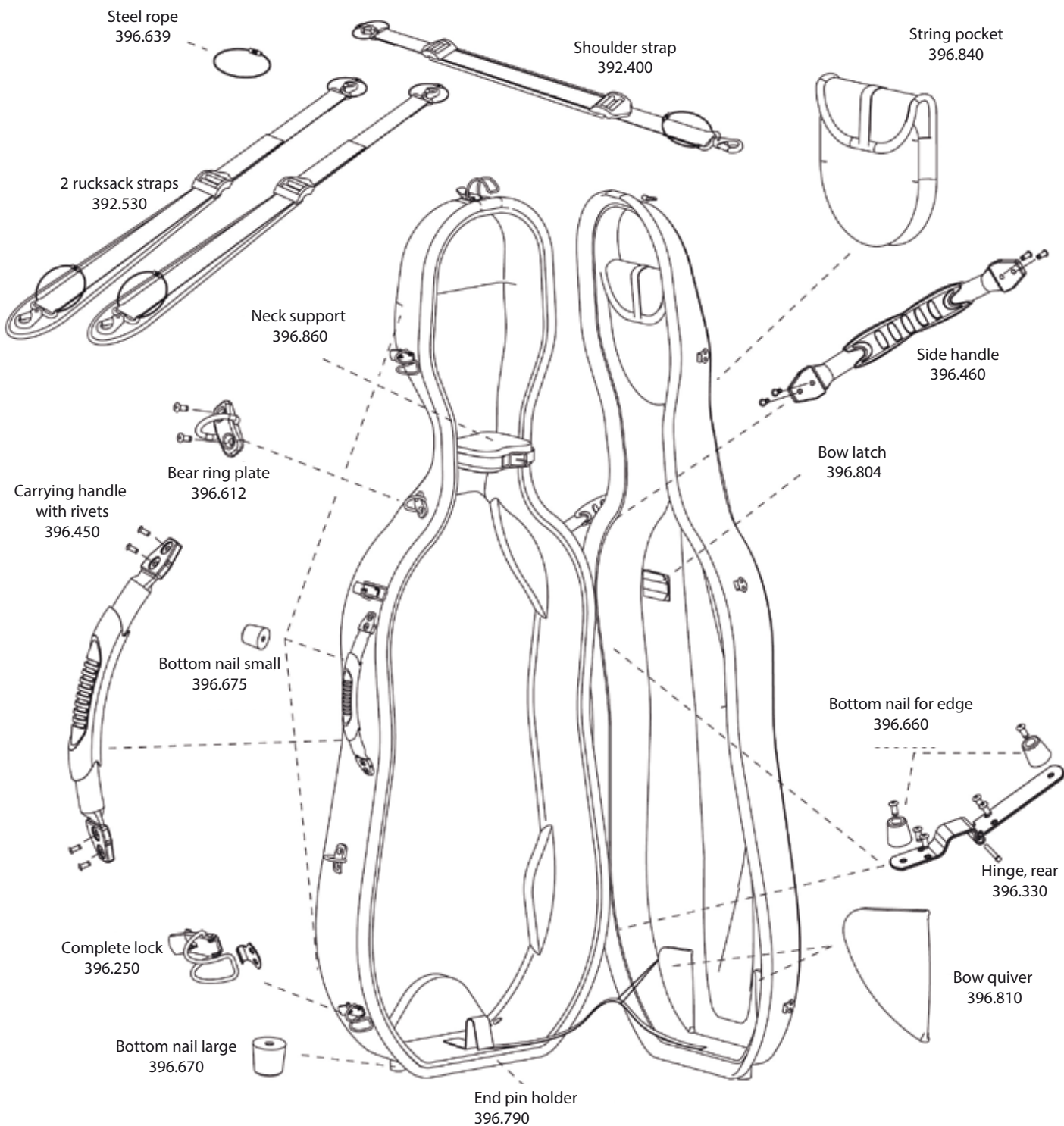

GEWA Strings

Carbon fibre mats, fiberglass mats are impregnated with resin and moulded. After hardening indissolubly connected. Extremely high torsion resistance, low weight, medium insulation qualities, excellent impact absorption.

GEWA Cello case Idea X-Lite 3.9

- **Made in Germany**
- Carbon fibre reinforced synthetic resin shell
- **Weight approx. 4,2 kg**
- Padded suspension system
- SPS-lock-system
- 4 GEWA special locks
- Accessory pocket
- 2 Detachable Neoprene rucksack straps
- Velour padding



342.210	black/burgundy
342.220	Pearl white/burgundy
342.230	platin grey/burgundy
342.235	azure blue / anthracite
342.240	Light red/anthracite
342.245	fir-tree green/anthracite

GEWA Cello case Idea X-Lite inner measurements in cm

Total length	Body upper width	Body lower width	Total height incl. bridge
129	37	46	30

342.517 – 342.541

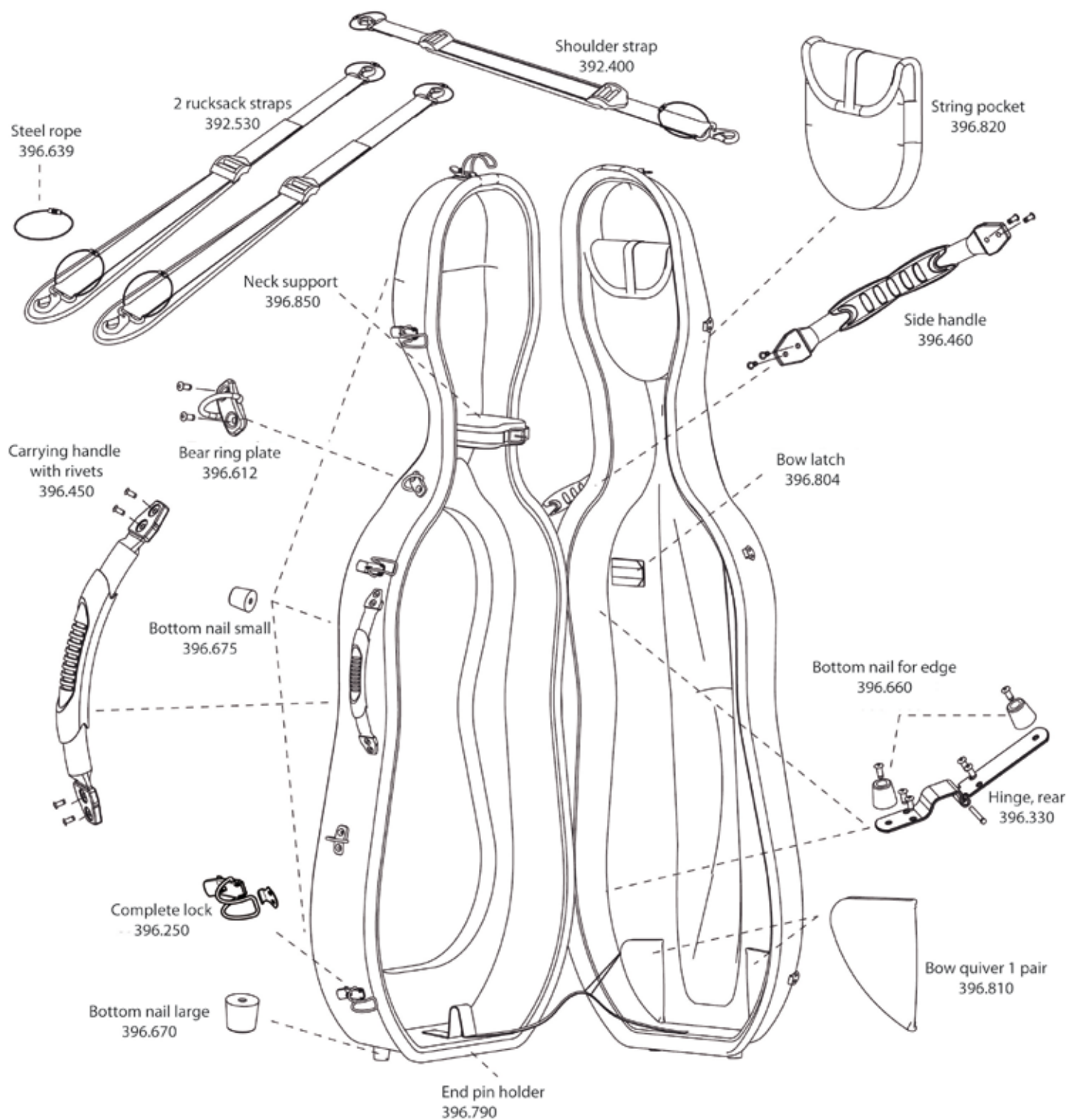

GEWA Strings

Cellists with a bigger cello model, e.g. Montagnana, choose the Idea Vario Plus. Adjustable interior padding allow for the fixation of the instrument. Fiberglass offers good protection for the instrument. High torsion resistance, low weight, medium insulation qualities, excellent impact absorption.

GEWA Cello case Idea Vario Plus

- Made in Germany
- Fibre glass reinforced synthetic resin shell
- Weight approx. 5,8 kg
- Padded suspension system
- SPS-lock-system
- 4 GEWA special locks
- Accessory pocket
- 2 Detachable Neoprene rucksack straps
- Over-size
- Velour padding

GEWA Cello case Idea Vario Plus inner measurements in cm

Total length	Body upper width	Body lower width	Total height incl. bridge
133	40	49	37



342.517 Dark blue/blue

GEWA Cello case carrying system Idea Fiedler

- Black nylon material
- Individually adjustable
- Large music sheet pocket
- Geometrical 6-point mounting
- Also usable as sitting pillow
- model FUTURA with Fiedler-carrying system



342.541 Dark blue/blue

GEWA Cello case carrying system Idea Comfort

- Detachable ruck-sack system
- Attachment without added fittings
- Black GEWA-Litex padding
- Music sheet pocket
- 2 padded carrying straps
- Illustration with FUTURA-case
- inner measurements 33 x 35 cm



342.525

343.370 – 343.384

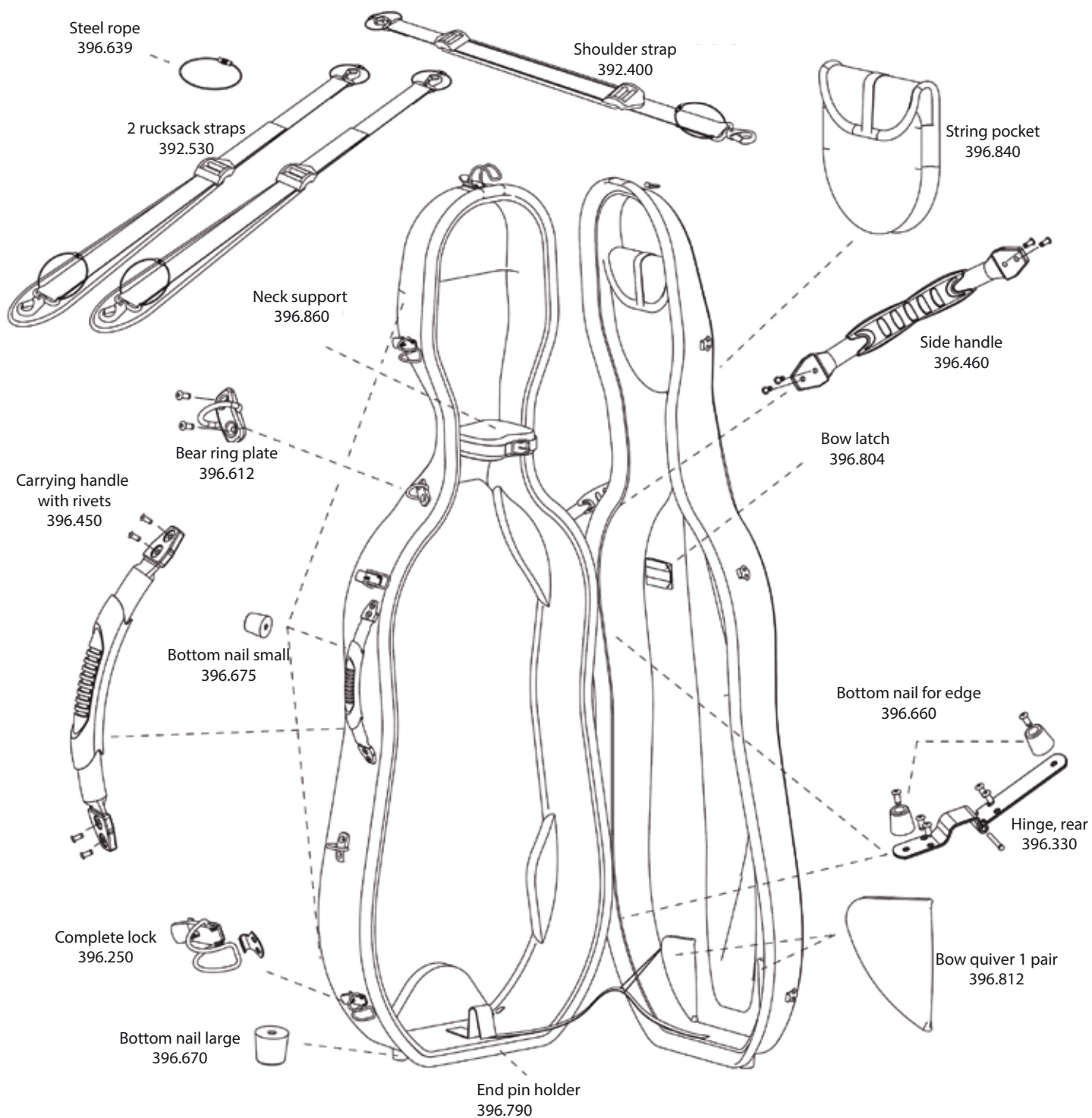

GEWA Strings

Carbon fibre mats, fiberglass mats are impregnated with resin and moulded. After hardening indissolubly connected. Extremely high torsion resistance, very low weight, medium insulation qualities, excellent impact absorption.

100% Aramid fibre mats are impregnated with resin and hardened in a special positioning in a mould. This fiber is particularly used in security technology for bulletproof waistcoats in personal protection. Highest torsion resistance, extremely low weight, medium insulation qualities, most excellent impact absorption.

GEWA Cello case Idea Titanium Carbon 3.3

- Made in Germany
- Carbon shell made of 80 % Hi-Tech carbon fit
- Weight approx. 3,3 kg
- Padded suspension system
- SPS-lock-system
- 4 GEWA special locks
- Accessory pocket
- 2 Detachable Neoprene rucksack straps
- Exterior carbon fibre titanium
- Interior velour padding



3,3 kg



343.370	Titanium/anthracite
343.372	Titanium/burgundy
343.374	Titanium/blue

GEWA Cello case Idea Aramid Carbon 3.1

- Made in Germany
- Aramid Carbon shell
- Very light approx. 3,1 kg
- Padded suspension system
- SPS-lock-system
- 4 GEWA special locks
- Accessory pocket
- 2 Detachable Neoprene rucksack straps
- Outside Aramid Carbon yellow/black
- Interior velour padding black

3,1 kg



343.375

100 % Carbon fibre mats are impregnated with resin and hardened in a special positioning in a mould under pressure and heat. The hardening results in an exceptionally durable shell in every respect. Carbon fibres are used with extreme requirements regarding weight and stability. Highest torsion resistance, lowest achievable weight, medium insulation qualities, most excellent impact absorption.

GEWA Cello case Idea Original Carbon 2.9

- Made in Germany
- Shell made of Hi-Tech carbon fibre fabric
- Ultra light approx. 2.9 kg
- Padded suspension system
- SPS-lock-system
- 4 GEWA special locks
- Accessory pocket
- 2 detachable Neoprene rucksack straps
- Exterior carbon fibre black
- Interior velour padding

2,9 kg



GEWA Cello case Idea Original Carbon inner measurements in cm

Total length	Body upper width	Body lower width	Total height incl. bridge
129	36	45	28

343.380	Interior anthracite
343.382	Interior bordeaux
343.384	Interior dark blue

GEWA Strings

GEWA Double bass case Idea Mammoth

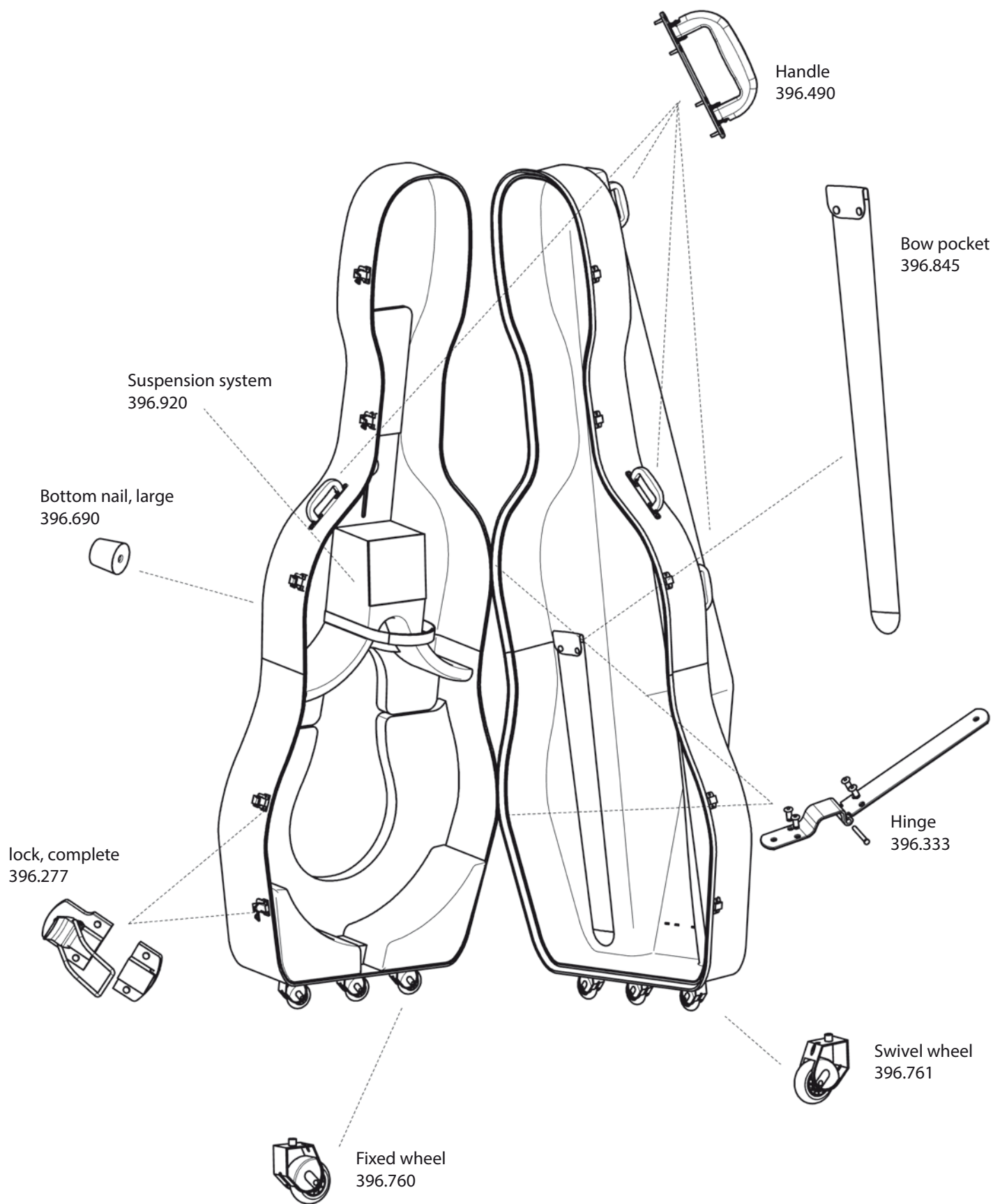

Not all parts included in delivery. Subject to change

GEWA Strings

A must for bassists who are constantly on concert tour and require a very safe protection for their double bass.

Fiberglass- the entry into the Idea world. Fiberglass mats are impregnated with resin and moulded in our own procedure.

High torsion resistance, low weight, medium insulation qualities, excellent impact absorption.

Adjustable interior for 4/4, 3/4, 1/2.

GEWA Double bass case Idea Mammoth

- **Made in Germany**
- **Fibreglass reinforced synthetic resin**
- **SPS-side protection system**
- Instrument suspension system
- Adjustable interior
- Accessory compartment, bow pockets
- Swivel wheels for easy transportation
- Weight approx 28 kg
- Exterior white
- Interior velour red



GEWA Double bass case Idea Mammoth interior measurements in cm

Total length	Body upper width	Body lower width	Total height incl. bridge
196	63	79	58

GEWA Double bass case Idea Mammoth exterior measurement in cm

Length	Width	Height
225	88	68



GEWA Strings

GEWA Bow case Maestro

350.100 - 350.146

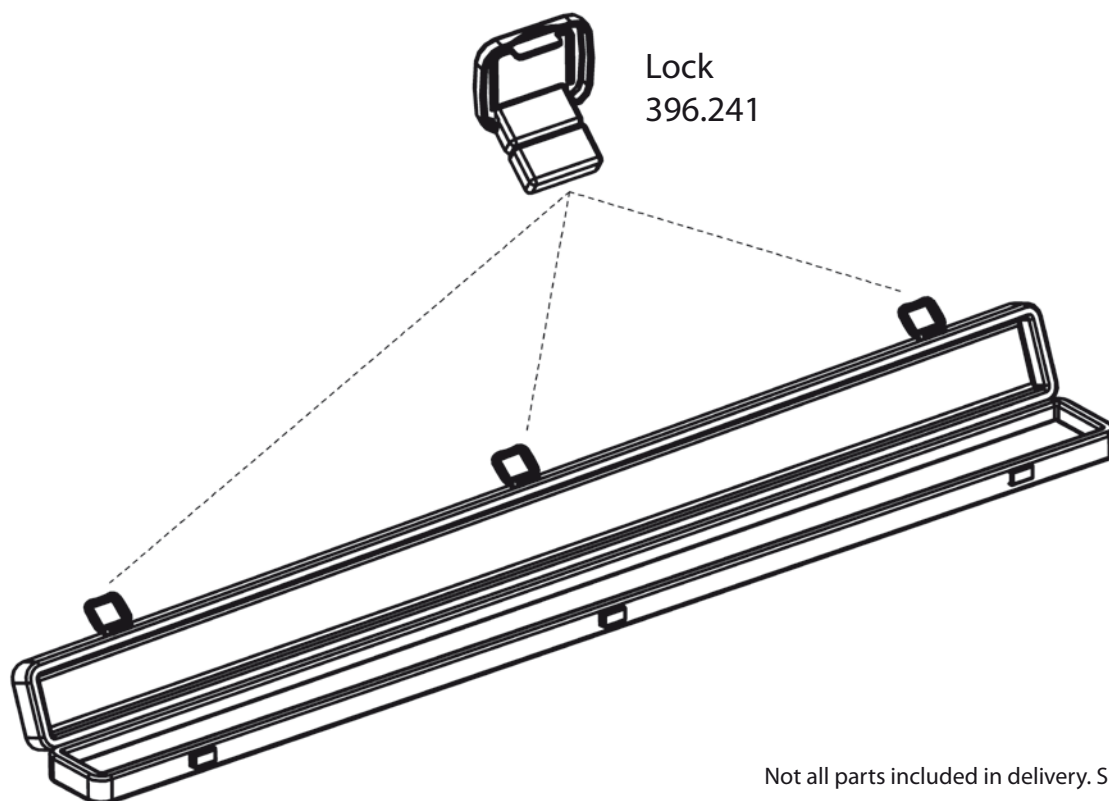

The Maestro bow cases are made in the classic wooden construction. They are very handy, also with a bigger number of bows, and are a must for orchestra musicians, instructors, students and bow makers who transport their bows independently from their instruments. The materials were specifically chosen for the respective designs.

GEWA Bow case Maestro

- 3 golden latches
- Reinforced edges
- Exterior: artificial leather
- Interior: velveteen
- 1 violin bow up to 74,5 cm

- 1 Bass bow German 81 cm



350.100* Black/Green

- 2 violin bows

350.105* Black/Green

- 1 cello bow up to 72,5 cm

350.120* Black/Green

- 2 Cello bows

350.125* Black/Green



350.140* Black/Green

- 1 bass bow french 73 cm

350.142* Black/Green

- 2 bass bows

350.145* Black/Green

GEWA Strings

GEWA Bow case Matrix

- Very stable and light-weight aluminium case
- 2 combination locks
- D-rings for shoulder strap
- Reinforced edges and corners
- Sturdy handle
- Inside velveteen
- Fits violin bows of up to 76 cm



350.160*	6 bows
350.170*	12 bows
350.180*	24 bows

PURE GEWA Bow case

- Screw attached cover with zipper
- Exterior Conatex black
- Interior velvet plush anthracite
- Single case



PS354.010*	Violin bow 0,5 kg
PS354.015*	Cello bow 0,52 kg
PS354.020*	Bass bow german 1,02 kg
PS354.025*	Bass bow french 0,98 kg

- Double case



PS354.040*	Violin bow 0,62 kg
PS354.045*	Cello bow 0,6 kg
PS354.050*	Bass bow german 1,44 kg

PURE GEWA Bow case

- Screw attached cover with zipper
- Straight storage
- Exterior Conatex black
- Interior velvet plush anthracite
- Bow Case with handle for 12 and 24 bows
- **Fitting for violin, viola and cello**



PS354.061*	6 bows
PS354.071*	12 bows
PS354.081*	24 bows

GEWA Strings

GEWA Rucksack assembly Form shaped violin/viola case

- Consists of two straps
- Web strap 30 mm wide
- Neoprene shoulder protection
- 4 GEWA carabiner
- Additional security thanks to steel rope with screw-closure



392.451* Gold-plated carabiner 55 - 80 cm

GEWA Cello case interior padding Idea

- Fitting for all GEWA Idea cello cases
- **Flexible interior pads**
- A special wedge protects the rib and provides a firm fit of the instrument
- Variable adjustment due to Velcro fastener
- Special bottom unit as a part of the suspension system
- Black warp pile velvet



396.780 5 parts for 7/8



396.781 3 parts for 3/4

GEWA MUSIC

GEWA music GmbH | Oelsnitzer Str. 58 | D-08626 Adorf
Tel. +49 (0) 37423 - 778 333 | Fax +49 (0) 37423 - 778 93 33
info@gewamusic.com | www.gewamusic.com